

Service Manual

QUARTZ Direct Drive Automatic Turntable System

SL-15

[E], [EK], [XL], [EG], [EB],
[EF], [XA], [XM], [EH], [Ei]

SL-15(K)

[E], [EK], [XL], [EG],
[EB], [EF], [XA], [XM], [EH]



* The colors of this model include silver and black.
* The black type model is provided with (K) in the Service Manual.

Areas

- * [E] is available in Switzerland and Scandinavia.
- * [EK] is available in United Kingdom.
- * [XL] is available in Australia.
- * [EG] is available in F.R. Germany.
- * [EB] is available in Belgium.
- * [EF] is available in France.
- * [XA] is available in Southeast Asia, Oceania, Africa, Middle Near East and Central South America.
- * [XM] is available in Central South America.
- * [EH] is available in Holland.
- * [Ei] is available in Italy.

English

Specifications

Specifications are subject to change without notice for further improvement.
Weight and dimensions shown are approximate.

■ General

Power supply:	~ 110-120/220-240 V, 50/60 Hz DC 12 V (DC input jack)
Power consumption:	20 W (AC) 6 W (DC)
Dimensions: (W x H x D)	31.5 x 8.8 x 31.5 cm (12-1/2" x 3-1/2" x 12-1/2") With the cabinet top open to maximum position: 31.5 x 38.5 x 31.5 cm (12-1/2" x 15-5/32" x 12-1/2")
Weight:	6.6 kg (14.3 lb.)

■ Turntable section

Type:	Quartz-phase-locked control direct-drive automatic turntable Automatic operation Programmable band selection Repeat play Program repeat 2-speed inward/outward search Program skip Program in-band repeat Auto start/Auto lead-in Auto return Auto stop Auto speed select Auto size select Record presence detection
-------	--

Drive method:	Direct drive
Motor:	Brushless DC motor
Drive control method:	Quartz-phase-locked control
Turntable platter:	Aluminum diecast Diameter 30 cm (12 inches)
Turntable speeds:	33-1/3 rpm and 45 rpm Auto speed select (Manual selection possible)
Speed deviation:	Within $\pm 0.002\%$
Wow and flutter:	0.012% WRMS* 0.025% WRMS (JIS C5521) $\pm 0.035\%$ peak (IEC 98A weighted)

*This rating refers to turntable assembly alone, excluding effects of record, cartridge or tonearm, but including platter.
Measured by obtaining signal from built-in frequency generator of motor assembly.

Rumble:	-56 dB (IEC 98A Unweighted) -78 dB (IEC 98A Weighted)
---------	--

■ Tonearm section

Type:	Dynamic balanced type Linear tracking tonearm 4-pivot gimbal suspension
Effective-mass:	9 g (including cartridge)
Tracking error angle:	Within $\pm 0.1^\circ$
Resonance frequency:	12 Hz
Tonearm drive motor:	Coreless DC motor

Technics

Matsushita Electric Trading Co., Ltd.
P.O. Box 288, Central Osaka Japan

■ Cartridge section

Type:	Moving magnet stereo cartridge Disc-shaped magnet One point suspension system
Magnet circuit:	All "HPF" core, precision ground finish
Cantilever:	Pure boron pipe
Damper:	TTDD (Technics Temperature Defense Damper)
Magnet:	Samarium-cobalt (Sm-Co) (BH) max. = 30 MG-Oe
Frequency response:	5 Hz — 80 kHz 15 Hz — 60 kHz ± 3 dB 20 Hz — 15 kHz ± 0.5 dB
Temperature characteristics: (5°C — 35°C)	± 0.5 dB (10 kHz) (0 dB at 1 kHz, 20°C) ± 2 dB (20 kHz) (0 dB at 1 kHz, 20°C)
Output voltage:	2 mV (1 kHz), 5 cm/s. zero to peak, lateral velocity (5.7 mV 1 kHz 10 cm/s. zero to peak, 45° velocity, DIN 45 500)

Channel separation:	More than 25 dB (1 kHz) More than 20 dB (10 kHz)
Channel balance:	Within 0.7 dB (1 kHz)
Compliance:	12 x 10 ⁻⁶ cm/dyne (100 Hz, dynamic)
Vertical tracking angle:	20°
DC resistance:	500 Ω
Inductance:	240 mH
Impedance:	1.6 k Ω (1 kHz)
Recommended load resistance:	47k Ω — 100 k Ω
Recommended load capacitance:	Less than 200 pF
Stylus tip:	0.2 x 0.7 mil (5 x 18 μm) Elliptical diamond stylus
Effective moving mass:	0.149 mg
Stylus pressure range:	1.25 ± 0.25 g (12.5 ± 2.5 mN)
Weight:	6 g (cartridge only)
Replacement stylus:	EPS-P205ED3

■ Accessories supplied:

Stylus cleaning brush	1
Screwdriver (large)	1
Screwdriver (small)	1

Deutsch

TECHNISCHE DATEN

Änderungen der technischen Daten vorbehalten.
Die angegebenen Gewichts- und Abmessungsdaten sind circa Werte.

■ Allgemeine Daten

Stromversorgung:	~ 110–120/220–240 V, 50/60 Hz Wechselstrom 12 V Gleichstrom (Ausgestattet mit Gleichstrom-Eingangsbuchse)
Leistungsaufnahme:	20 W (Wechselstrom) 6 W (Gleichstrom)
Abmessungen: (B x H x T)	31,5 x 8,8 x 31,5 cm (Bei vollständig geöffnetem Gehäuseoberteil: 31,5 x 38,5 x 31,5 cm)
Gewicht:	6,6 kg

■ Plattenspieler

Typ:	Automatischer Quarzgesteuerter Direktantrieb-Plattenspieler Automatischer Betrieb Programmierbare Musikstück-Auswahl Wiederholtes Abspielen Programm-Wiederholung Suchlauf nach innen/außen mit 2 Geschwindigkeiten Programm-Überspringen Wiederholung im programmierten Musikstück Auto-Start/Auto-Zuführung Rückführautomatik Stopp-Automatik Automatische Drehzahlwahl Automatische Plattengrößewahl Plattenpräsenz-Registrierung
Antrieb:	Direktantrieb
Motor:	Kollektorloser Gleichstrommotor
Antriebsregel-Methode:	Quarz-Steuerung (QPL)
Plattenteller:	Aluminium-Druckguß Durchmesser 30 cm
Plattenteller-Drehzahlen:	33-1/3 und 45 U/min Automatische Drehzahlwahl (manuelle Wahl möglich)

Drehzahlabweichung:	Innerhalb ± 0,002%
Gleichlaufschwankungen:	0,012% WRMS* 0,025% WRMS (JIS C5521) ± 0,035% Spitze (IEC 98A bewertet)

*Diese Nennleistung bezieht sich auf das Laufwerk-Bauteil allein, ausschließlich Einflüsse von Schallplatte, Tonabnehmer oder Tonarm, aber einschließlich Plattenteller. Gemessen anhand von Signalen vom eingebauten Frequenzgenerator des Motorbauteils.

Rumpel-Fremdspannungsabstand:	–56 dB (IEC 98A unbewertet)
Rumpel-Geräuschspannungsabstand:	–78 dB (IEC 98A bewertet)

■ Tonarm

Typ:	Dynamisch ausbalancierter Tangential-Tonarm mit Kardanaufhängung mit 4-Punkt-Drehlager
Effektive Masse:	9 g (einschließlich Tonabnehmer)
Spurfehlwinkel:	Innerhalb ± 0,1°
Resonanzfrequenz:	12 Hz
Tonarm-Antriebsmotor:	Kernloser Gleichstrommotor

■ Tonabnehmer

Typ:	Magnetischer Stereo-Tonabnehmer (MM), Scheibenförmiger Magnet, Einpunkt-Aufhängungssystem
Magnetschaltung:	Ganz-"HPF"-Kern, Präzisionsschliff-Verarbeitung
Nadelträger:	Röhre aus reinem Bor
Dämpfer:	TTDD (Technics Temperature Defense Damper)
Magnet:	Samarium-Kobalt (Sm-Co) (BH) max. = 30MG-Oe
Frequenzgang:	5 Hz — 80 kHz 15 Hz — 60 kHz ± 3 dB 20 Hz — 15 kHz ± 0,5 dB

Temperatureigenschaften: (5°C–35°C)	± 0,5 dB (10 kHz) (0 dB bei 1 kHz, 20°C) ± 2 dB (20 kHz) (0 dB bei 1 kHz, 20°C)
Ausgangsspannung:	2 mV bei 1 kHz 5 cm/s. Null-zu-Spitze, lateral [5,7 mV bei 1 kHz 10 cm/s. Null-zu-Spitze, 45° (DIN 45 500)]
Kanaltrennung:	Mehr als 25 dB bei 1 kHz Mehr als 20 dB bei 10 kHz
Kanalabweichung:	Innerhalb 0,7 dB bei 1 kHz
Nachgiebigkeit:	12 x 10 ⁻⁶ cm/dyn bei 100 Hz
Vertikaler Spurwinkel:	20°
Gleichstromwiderstand:	500 Ω
Induktivität:	240 mH
Impedanz:	1,6 k Ω bei 1 kHz

Empföhler	
Belastungswiderstand:	47 k Ω — 100 k Ω
Empföhlene	
Belastungskapazität:	Weniger als 200 pF
Nadelspitze:	0,2 x 0,7 Mil (5 x 18 μm) Elliptische Diamantnadel
Effektive bewegliche	
Masse:	0,149 mg
Aufiagerkraft-Einstellbereich:	1,25 ± 0,25 g (12,5 ± 2,5 mN)
Gewicht:	6 g (nut Tonabnehmer)
Ersatznadel:	EPS-P205ED3

■ Mitgeliefertes Zubehör

Nadel-Reinigungspinsel	1
Schraubenzieher (groß)	1
Schraubenzieher (klein)	1

Français

CARACTERISTIQUES

Les spécifications sont susceptibles d'être modifiées sans préavis.
Le poids et les dimensions donnés sont approximatifs.

■ Généralités

Alimentation:	Alternatif 110–120/220–240 V, 50/60 Hz 12V C.C. (borne d'entrée C.C.) 20 W (C.A.) 6 W (C.C.)
Consommation:	
Dimensions: (L x H x P)	31,5 x 8,8 x 31,5 cm (12-1/2" x 3-1/2" x 12-1/2") Avec le dessus du boîtier ouvert à la position maximale: 31,5 x 38,5 x 31,5 cm, (12-1/2" x 15-5/32" x 12-1/2")
Poids:	6,6 kg (14,3 livres)

■ Platine de lecture

Typ:	Platine automatique à entraînement direct à réglage d'asservissement de phase par quartz. Fonctionnement automatique Sélection de plage programmable Audition répétée Répétition de programmes Fonction de recherche à 2 vitesses vers l'intérieur/extérieur Omission de programmes Répétition de la plage programmée Départ automatique/Entrée automatique Retour automatique Arrêt automatique Sélection de vitesse automatique Sélection de diamètre automatique Détection de la présence d'un disque
-------------	---

Système d'entraînement:	Entraînement direct
Moteur:	Moteur C.C. sans balai
Groupe de réglage:	Réglage d'accrochage de phase par quartz
Plateau de lecture:	Aluminium moulé sous pression Diamètre 30 cm (12 pouces)
Vitesses de rotation:	33-1/3 et 45 t/p.m. Sélecteur de vitesse automatique (Sélection manuelle possible)
Déviations de la vitesse:	En deçà de ± 0,002%
Pleurage et scintillement:	0,012% de valeur efficace* 0,025% de valeur efficace (JIS C5521) ± 0,035% de crête (IEC 98A Pondéré)

*Ce régime nominal se rapporte à l'ensemble du tournedisque seul, excluant les effets du disque, de la cellule pick-up ou du bras de lecture, mais comprenant le plateau, Mesuré par l'obtention d'un signal provenant du générateur de fréquences incorporé de l'ensemble du moteur.

Ronflement:	–56 dB (IEC 98A Non pondéré) –78 dB (IEC 98A Pondéré)
--------------------	--

■ Bras de lecture

Typ:	Bras de lecture à alignement linéaire de type à équilibre dynamique avec suspension à la cardan à 4 pivots. 9 g (y compris la cellule pick-up)
-------------	---

Masse réelle:	
Angle d'erreur d'alignement:	En deçà de ± 0,1°
Fréquence de résonance:	12 Hz
Moteur d'entraînement du bras de lecture:	Moteur C.C. sans noyau

■ Cellule pick-up

Typ:	Cellule pick-up stéréo à aimant mobile. Aimant en forme de disque. Système de suspension ponctuelle.
Circuit magnétique:	Noyau entièrement en ferrite comprimé à chaud (HPF), finition précise de la masse.
Porte-à-faux:	Tube à bore pur
Amortisseur:	TTDD (Technics Temperature Defense Damper)
Aimant:	Samarium-Cobalt (Sm-Co) (BH) max. = 30 MG-Oe
Réponse en fréquence:	5 Hz — 80 kHz 15 Hz — 60 kHz ± 3 dB 20 Hz — 15 kHz ± 0,5 dB

Caractéristiques de température: (5°C–35°C)	± 0,5 dB (10 kHz) (0 dB à 1 kHz, 20°C) ± 2 dB (20 kHz), (0 dB à 1 kHz, 20°C)
Tension de sortie:	2 mV à 1 kHz; 5 cm/s., zéro à vitesse latérale de crête (5,7 mV à 1 kHz; 10 cm/s., zéro à vitesse 45° de crête [DIN 45 500])
Séparation des canaux:	Plus de 25 dB à 1 kHz Plus de 20 dB à 10 kHz
Equilibrage des canaux:	En deçà de 0,7 dB à 1 kHz
Elasticité:	12 x 10 ⁻⁶ cm/dyne (100 Hz dynamique)

Angle d'alignement vertical:	20°
Résistance C.C.:	500 Ω
Inductance:	240 mH
Impédance:	1,6 kΩ à 1 kHz
Résistance de charge recommandée:	47 kΩ ~ 100kΩ
Capacité de charge recommandée:	Moins de 200 pF
Extrémité de la pointe de lecture:	0,2 x 0,7 mil (5 x 18μm) Pointe de lecture à diamant ellipsoïdal

Masse de déplacement réelle:	0,149 mg
Plage de la force verticale d'appui:	1,25 ± 0,25 g (12,5 ± 2,5 mN)
Poids:	6 g (cellule seule)
Pointe de lecture de remplacement:	EPS-P206ED3
Accessoires fournis:	
Brosse de nettoyage pour la pointe de lecture	1
Tournevis (grand)	1
Tournevis (petit)	1

CONTENTS

DESCRIPTION OF CONTROLS	Page
GENERAL	4 ~ 6
ASSEMBLY INSTRUCTIONS	6, 7
DESCRIPTION OF CONNECTOR	8 ~ 12
DESCRIPTION OF CONNECTOR	13
SYMPTOMS AND ADJUSTMENTS (English)	13 ~ 17
SYMPTOMS DUE TO DEFECTIVE ADJUSTMENTS OF THE PROGRAM SELECTION CIRCUIT	17
SYMPTOMEN UND JUSTIERUNGEN (Deutsch)	18 ~ 20
SYMPTOMES ET RÉGLAGES (Français)	21 ~ 23
DOUBLE SHOOTING	24, 25
ABOUT THE OPTICAL SENSOR SENSITIVITY (GAIN) SELECTOR	25

REPLACEMENT PARTS LIST	Page
Electrical Parts	25 ~ 27
Cabinet & Chassis Parts	34, 39
CIRCUIT BOARD AND WIRING	
CONNECTION DIAGRAM	28 ~ 33
EXPLODED VIEWS	35 ~ 39
SCHEMATIC DIAGRAM	40 ~ 46
DESCRIPTION OF EACH TERMINAL OF MN1405PD	43 ~ 46
BLOCK DIAGRAM	47 ~ 49
PACKINGS	50

LOCATION OF CONTROLS

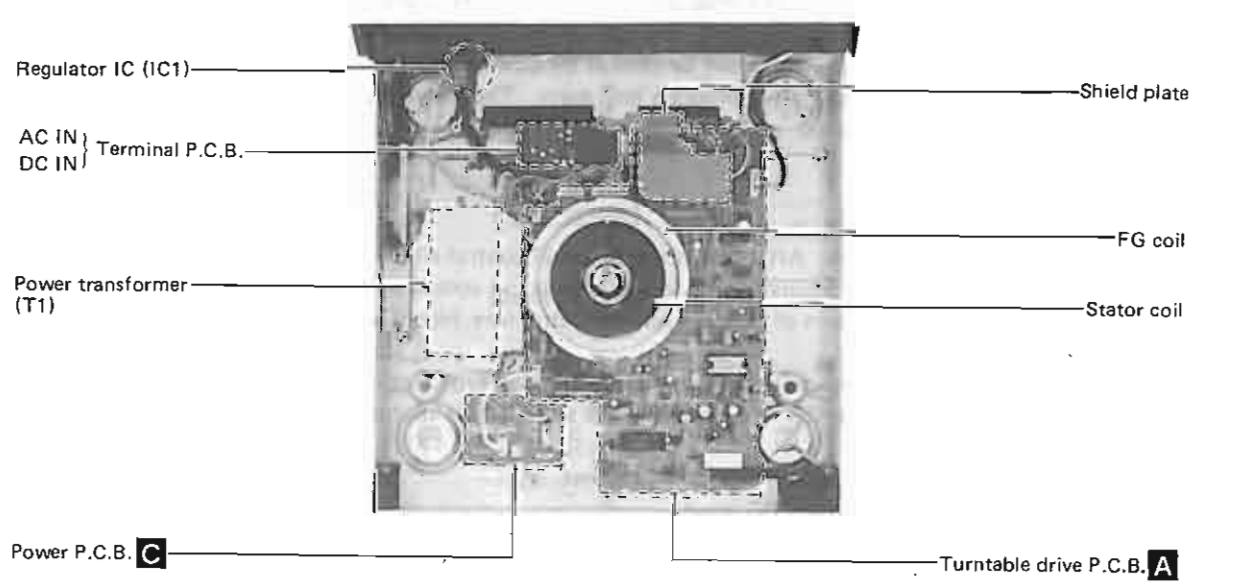
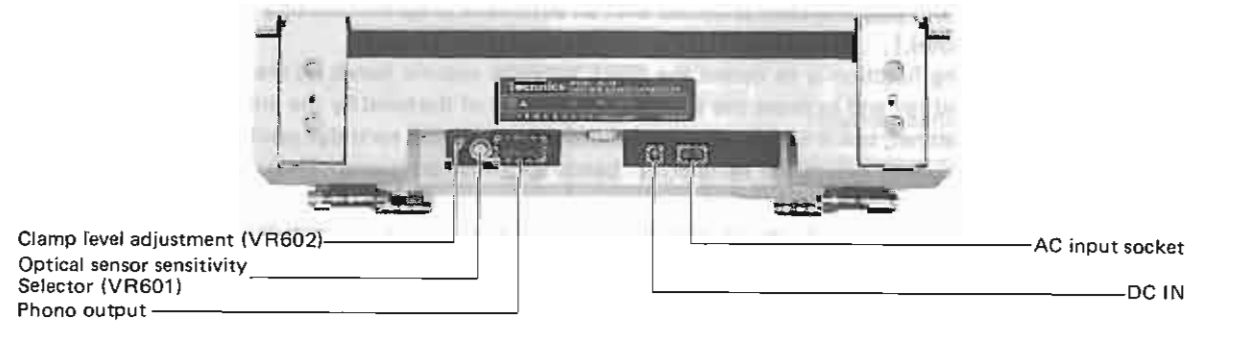
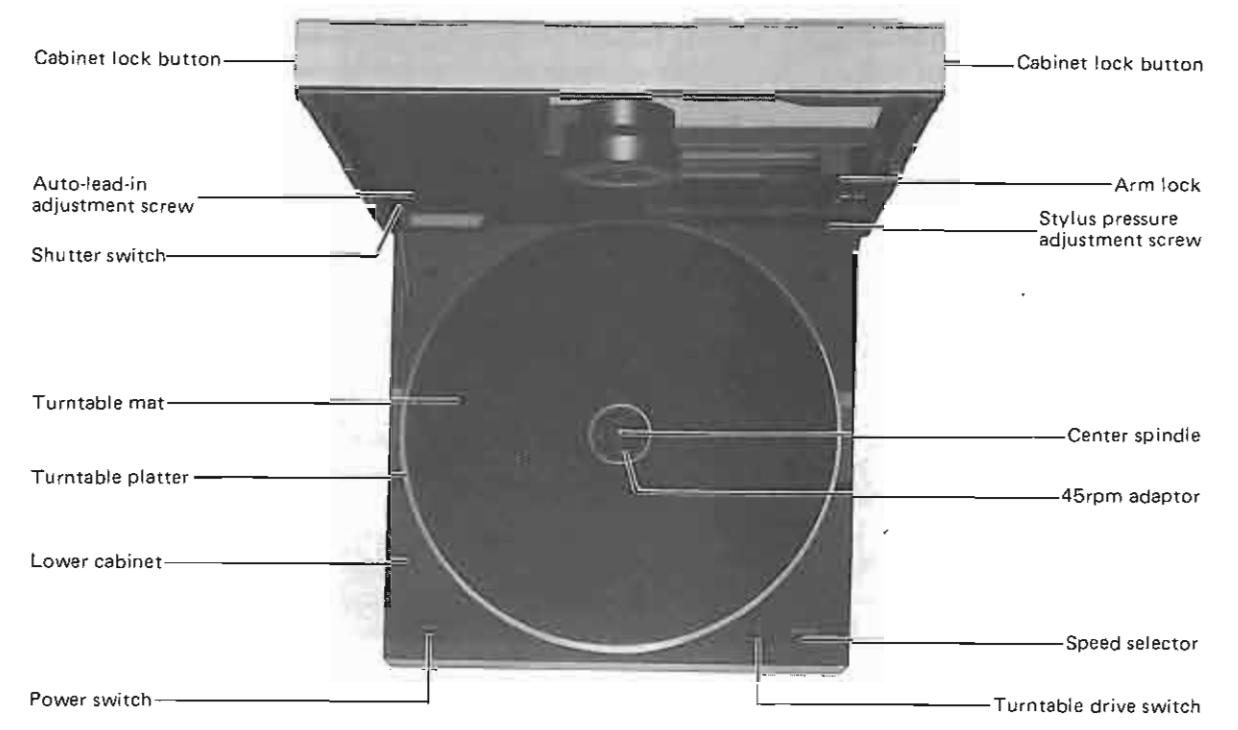
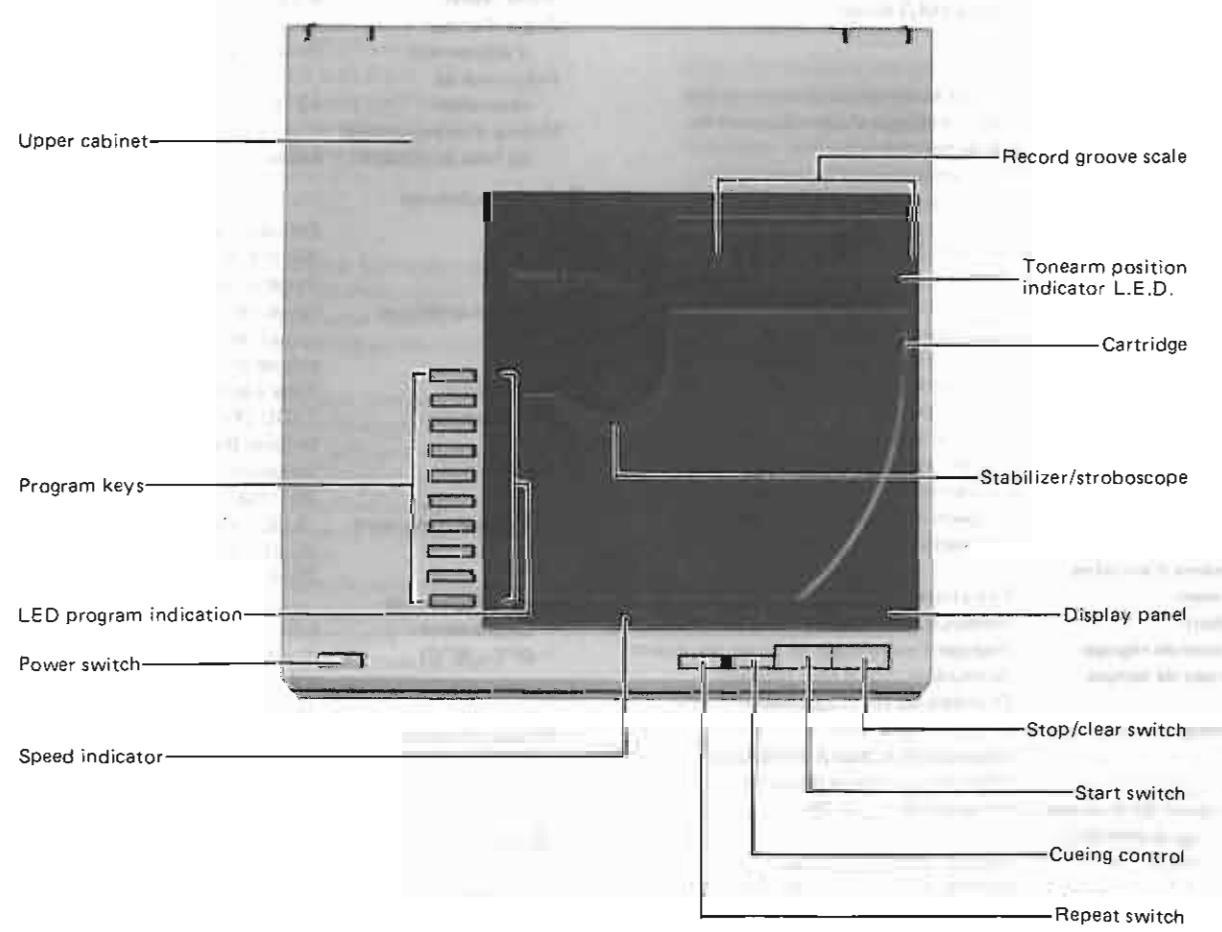

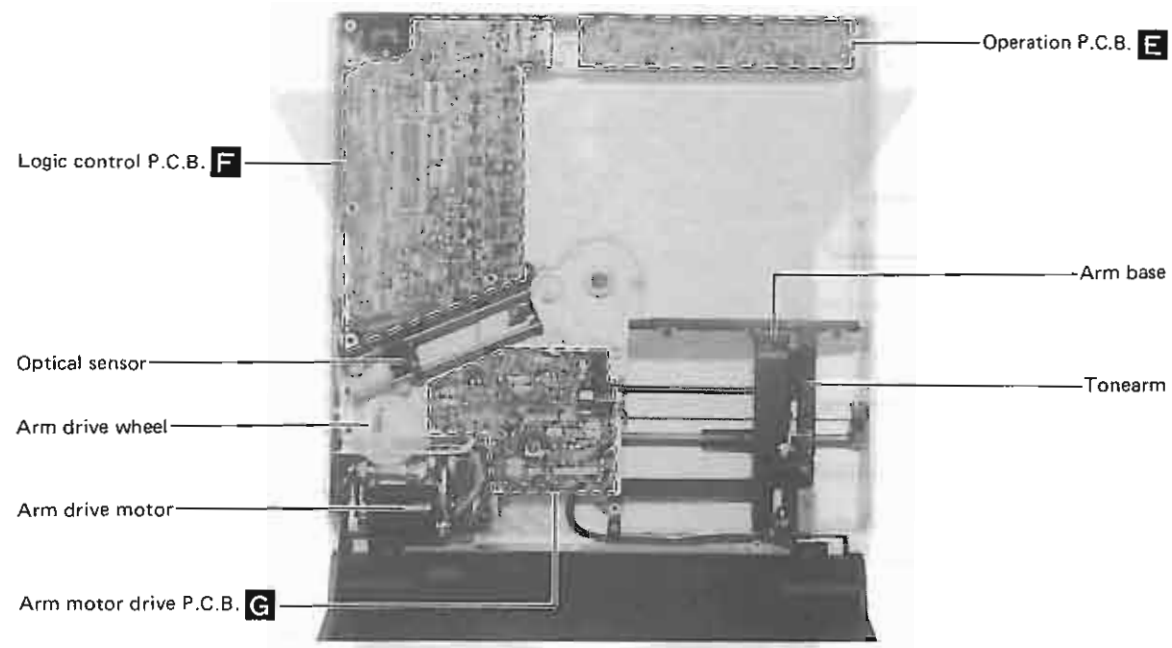

• Automatic program selection (See Fig. A)

The optical sensor unit in the upper cabinet is interlocked with the tonearm. The infrared ray radiated from the infrared LED of the Sensor is cast on the record disc, and the reflected ray is received by the photo transistor. The reflection factor is higher at the blank groove causing the amount of light entering the photo transistor to increase. At the sound groove, the amount of light entering the photo transistor decreases due to diffused reflection. The blank between bands is found by detecting the difference in reflection factor between the blank and sound grooves. The reflected signal is then processed by the microcomputer to control the tonearm operation.

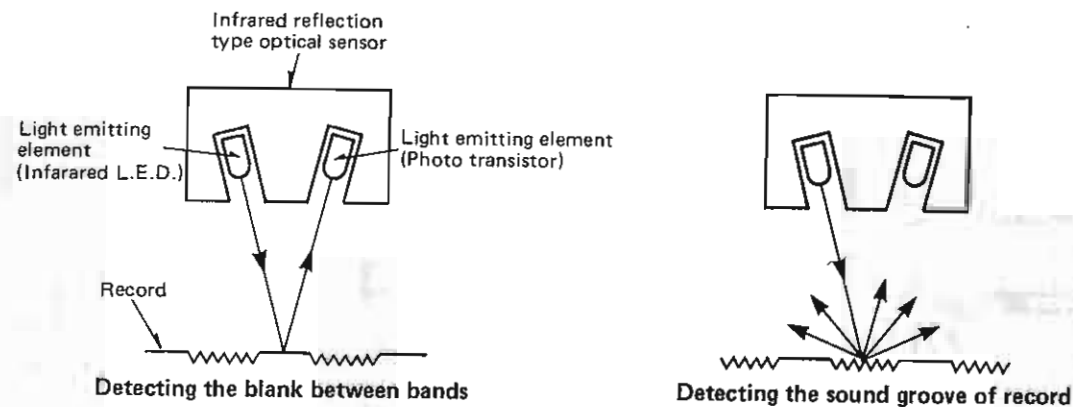

Fig. A

■ GENERAL

This is a high efficiency quartz DD player system provided with an automatic program selecting function, taking over the size and functions of SL-10 [See (Note).].

The automatic program selecting function is to detect the blank between specific bands on the record disc by the reflection type optical sensor using infrared ray and to move the tonearm to the head of the band by the microcomputer. This detecting sensor is built into the upper cabinet, but it is located away from the tonearm and cartridge positions, and is interlocked with the tonearm operating mechanism to detect the number of bands and their positions. Thus, the detection system is very unique.

Normal operation of this unit without touching the program keys brings about the same functions as those of SL-10. When the program keys are touched, the tonearm once moves to the inner periphery of the record, while the reflection type optical sensor reads the number of bands and their positions on the record; then, pushing start key causes the tonearm to play the programmed bands in order.

For example, when the start key is pushed after setting the program keys 2, 5, 3, 1 and 4 in order, the 2nd, 5th, 3rd, 1st and 4th programs are played in order. During the play, the program LED blinks indicating the position of band being played. Also, with it interlocked with the repeat key, the programs can be continuously played in the order of 2nd, 5th, 3rd, 1st and 4th bands. When desired to repeat only the 3rd band, the purpose can be achieved by pushing the program key 3 and interlocking it with the repeat key. All the programs can be cleared by pushing the stop key. Before pressing the start key, the selected program can be canceled by pushing the program key again. This player system is really full of enjoyment having multiple functions such as skipping and selecting of the programs.

Note: Features of SL-10

1. Quartz DD compacted to record jacket size.
Set the record and push the start switch. After that, the player will control all the functions.
2. Linear tracking tonearm having highly accurate servo function based on optical sensor (optical non-contact detection).
Because of the dynamic balance tonearm of gimbal suspension structure, highly accurate tracking is attainable irrespective of the player positions.
3. The basic control is very simple, and in addition, it is of multi-function type that is favorably accepted by enthusiasts.
4. The Technics' unique single structure DD, incorporating the rotor of the motor into the turntable, and the entire periphery detection FG are employed.
5. Precision aluminum die-cast two-layer (upper and lower) cabinet.
6. Two-power source system, capable of using DC power.
7. Strobe-attached stabilizer for holding the record.
8. Adapter (45 r.p.m) built-in.
9. Dial scale to check the tonearm position.

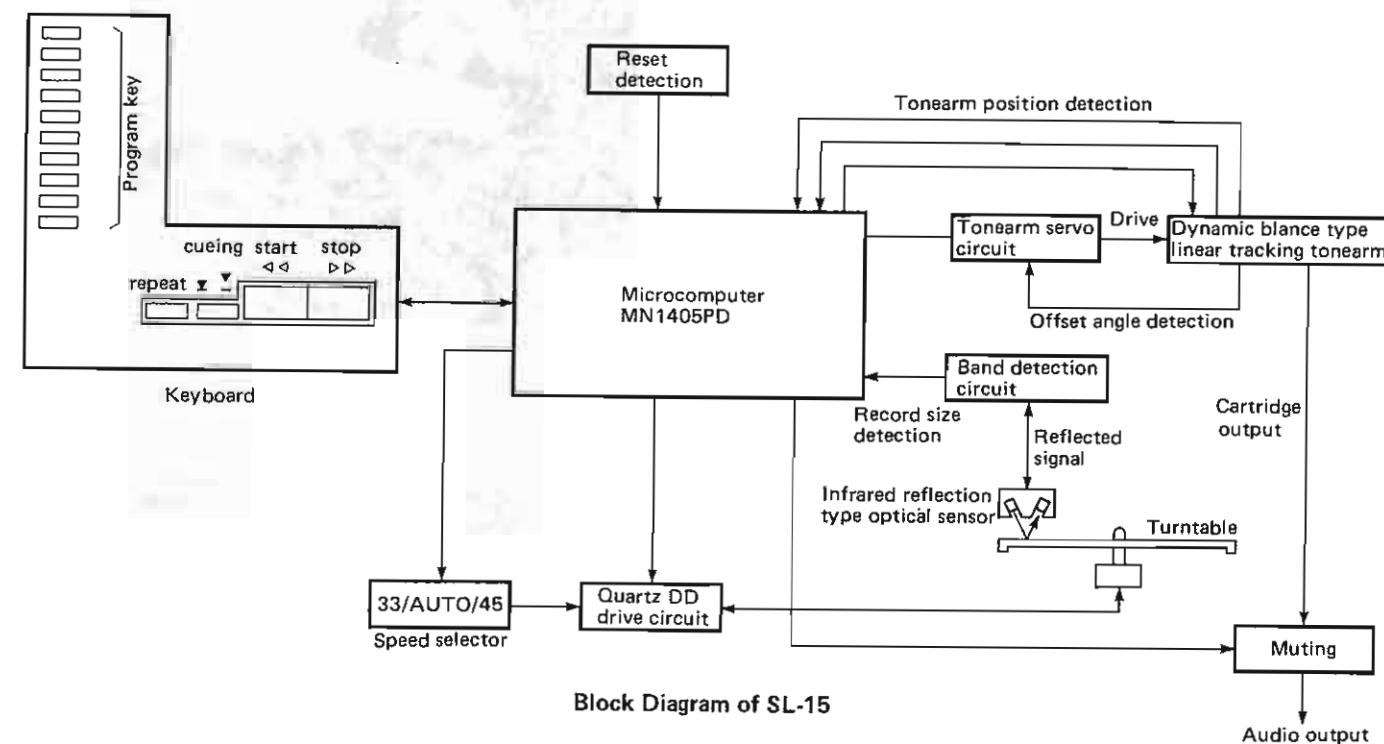

DISASSEMBLY INSTRUCTIONS

How to remove the cartridge

1. Push the lock button and slowly open the upper cabinet.
2. Lock the tonearm by sliding the arm lock. (See Fig. 1)
3. Loosen the cartridge setscrew with the screwdriver (large). (Loosen the screw until it is freed as illustrated.) (Fig. 2)

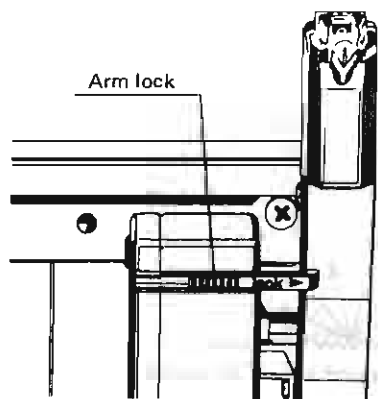

Fig. 1

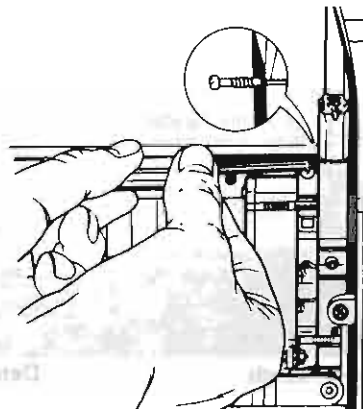

Fig. 2

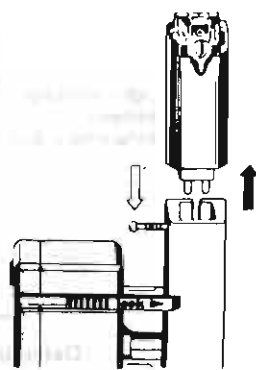

Fig. 3

4. Pull out the cartridge taking care not to touch the stylus tip. (See Fig. 3)
5. When installing the cartridge, match the cartridge pin with the tonearm connector, completely insert the pin and then tighten the setscrew.

How to remove the turntable

1. Holding the turntable with the hand, turn the adapter (45 r.p.m) counterclockwise to remove. (See Fig. 4)
2. Remove the nut ① and washers ②, ③ which secure the turntable. (See Fig. 5)
3. Fit two M3 screws (over 30mm in length) into the two holes provided near the center spindle of the turntable. Thus, the turntable can be removed by pulling up the screws with both hands.

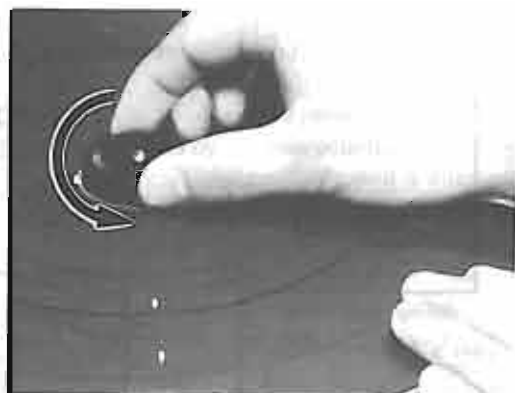

Fig. 4

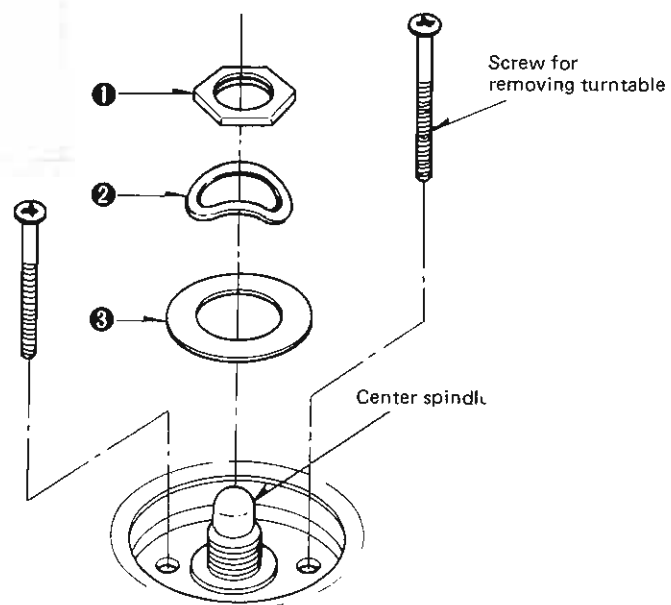

Fig. 5

How to remove the body cover

1. Completely open the upper cabinet, pull the stay toward you and remove it from the damper. (See Fig. 6)
2. Remove the turntable. (Refer to "How to remove the turntable".)
3. Remove the cover of the power source P.C.B. and detach the connectors ④ and ⑤ from the connector ⑥ of the drive P.C.B. (See Fig. 7)
4. Remove the 4 rubber caps of the body cover; remove the body cover setscrews ⑦ ~ ⑮; then the body cover can be removed. (See Fig. 7)

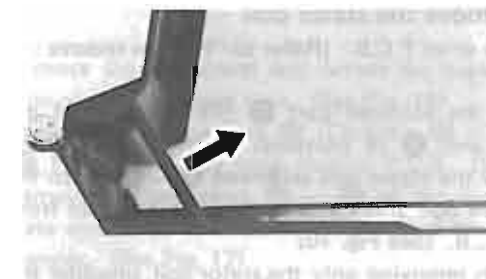

Fig. 6

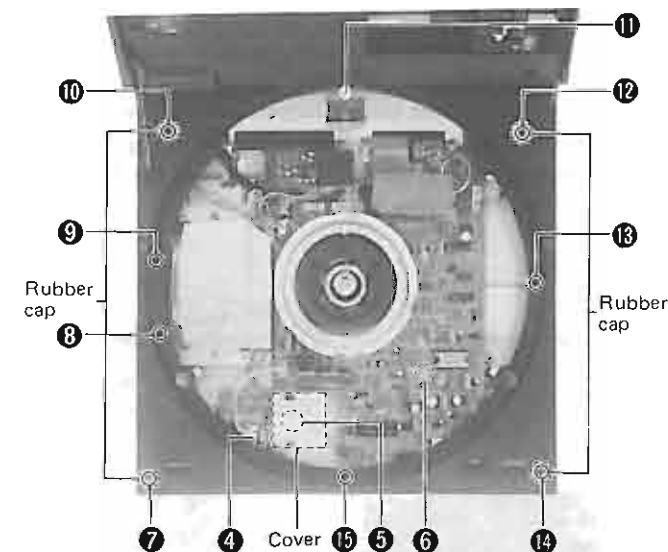

Fig. 7

How to remove the drive P.C.B.

1. Remove the body cover. (Refer to "How to remove the body cover".)
2. Remove the shield cover setscrew ⑮ and drive circuit board setscrews ⑰ ~ ⑳. (See Fig. 8)

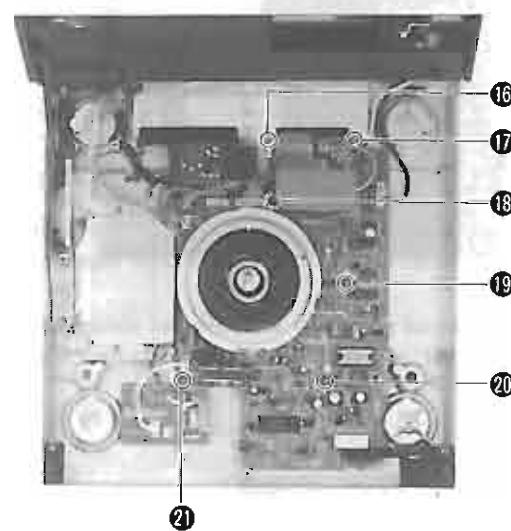

Fig. 8

3. Remove the 6 connectors ⑳ ~ ㉓ and stator cover setscrews ㉔ ~ ㉖. (See Fig. 9)
4. Remove the IC1 setscrew ㉗; then the drive P.C.B. can be removed. (See Fig. 9)

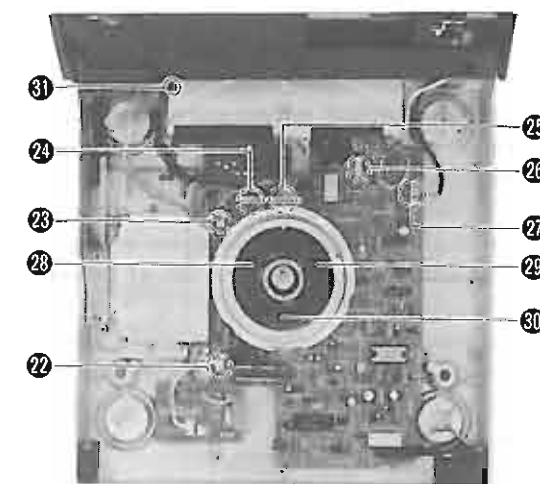

Fig. 9

How to remove the stator coil

Remove the drive P.C.B. (Refer to "How to remove the drive P.C.B".)

Disconnect the soldered part ① (18 portions) of the stator coil and ② (4 portions) of the FG detection coil; remove the stator coil setscrews ③ ~ ⑤, then the FG detection coil and stator coil can be removed from the drive P.C.B. (See Fig. 10)

Note: When removing only the stator coil, unsolder the part ① (18 portions) and remove the setscrews ③ ~ ⑤.

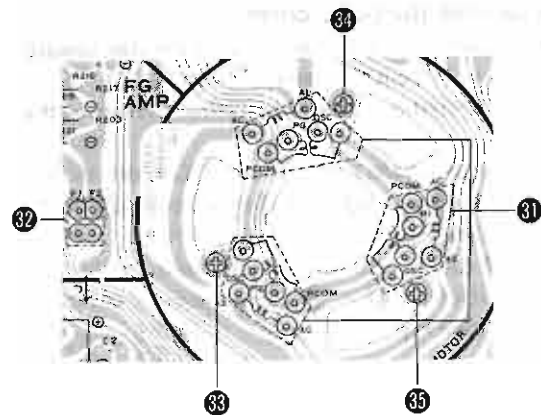

Fig. 10

How to remove the dust cover

Keeping the upper cabinet closed, loosen and remove the dust cover holder with a screwdriver as shown in Fig. 11. Remove the dust cover setscrews ⑥ ~ ⑧; then the dust cover can be removed. (See Fig. 12)

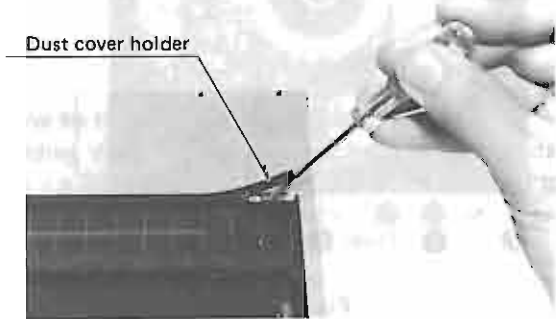

Fig. 11

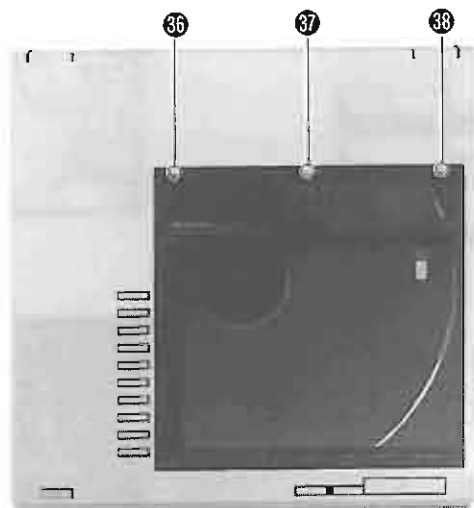

Fig. 12

How to remove the upper cover

Shift the tonearm inwards, and set the power switch to "off".

Remove the cartridge. (Refer to "How to remove the cartridge".)

Remove the dust cover. (Refer to "How to remove the dust cover".)

Completely open the upper cabinet and remove the stay from the damper. (See Fig. 6)

Remove the upper cover setscrews ⑨ ~ ⑩; insert a screwdriver between the cabinet and upper cover as in Fig. 14 from above the cabinet (near arrow in Fig. 13); then push the screwdriver in the direction of the arrow to remove the upper cover.

Note: When mounting the upper cover, make sure that the part of Fig. 14 is engaged with the upper cover and that the cover switch (S301) is outside the cover.

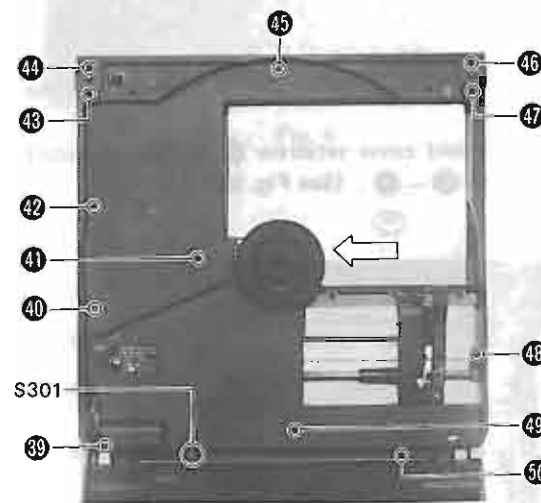

Fig. 13

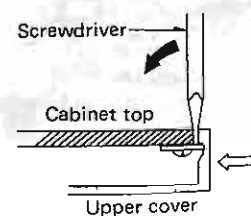

Fig. 14

How to remove the logic control P.C.B., arm motor drive P.C.B. and operation P.C.B.

1. Remove the upper cover. (Refer to "How to remove the upper cover".)

2. Remove the logic control P.C.B. setscrews ⑪ ~ ⑬. (See Fig. 15)

3. Remove the connector ⑭ (CN204) and ⑮ (CN401) of the logic control P.C.B.; remove the setscrews ⑯ ~ ⑰ of the operation P.C.B. then the operation P.C.B. can be removed. (See Fig. 15)

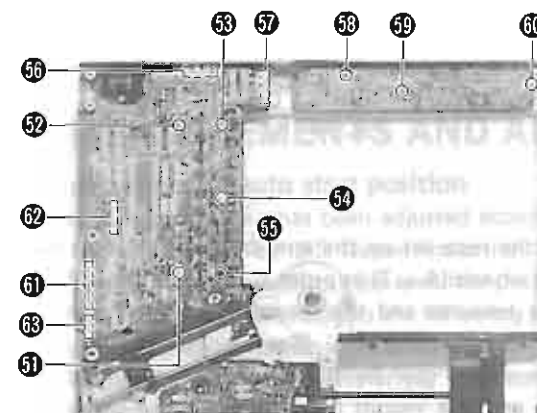

Fig. 15

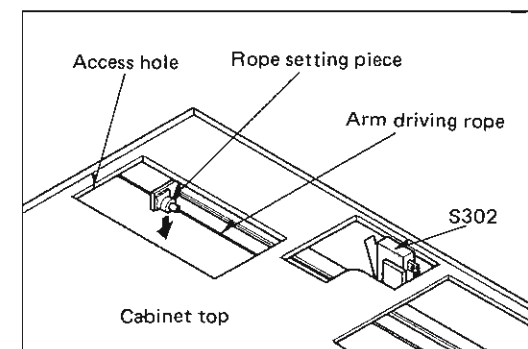

Fig. 16

How to remove the tonearm unit

1. Remove the body cover and upper cover. (Refer to "How to remove the body cover" and "How to remove the upper cover".)

2. Remove the tonearm drive plate assembly. (Refer to "How to remove the logic control P.C.B., arm motor drive P.C.B. and operation P.C.B.")

3. Remove the two connectors ㉞ (PHONO IN) and ㉟ (CN204) of the drive P.C.B.; remove the bushing ㊱ and lead clamber setscrew ㊲ of the upper cabinet. (See Fig. 18)

4. Remove the guide rail setscrew ㊳ of the tonearm; then the tonearm unit can be removed. (See Fig. 18)

4. Remove the dust cover and detach the tonearm driving rope out of the access hole. (See Fig. 16)

5. Remove the connectors ① (CN404), ② (CN405) and ③ (CN403) of the logic control P.C.B. (See Fig. 15)

6. Remove the setscrews ④ ~ ⑥ of the tonearm drive plate assembly, and disconnect the lead wires from the clamber. (See Fig. 17)

7. Remove the setscrew ⑦ of the arm motor drive P.C.B. the connector ⑧ (CN303) and ⑨ (CN301); then the arm motor drive P.C.B. can be removed. (See Fig. 17)

8. When removing the logic control P.C.B. completely, remove the body cover and two connectors (CN201, CN202) of the drive P.C.B.; detach the bushing ⑩ of the upper cabinet; then the logic control P.C.B. can be removed. (See Fig. 17)

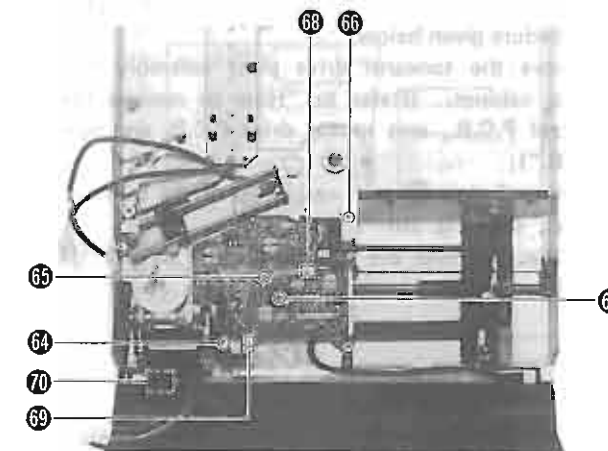

Fig. 17

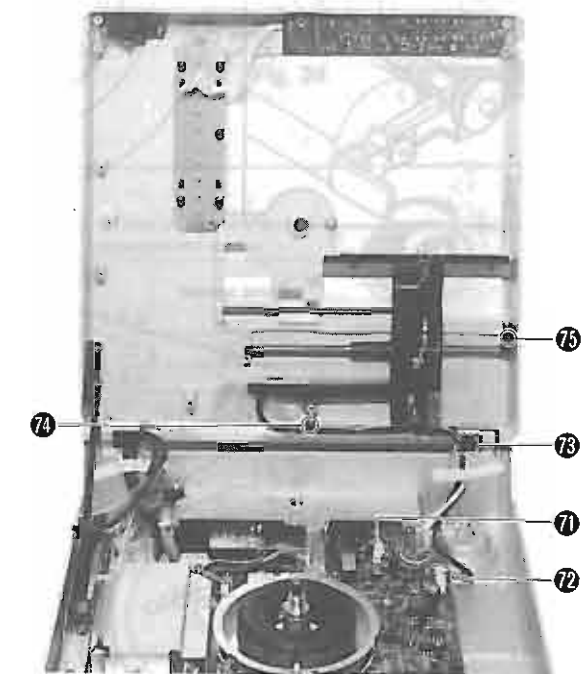
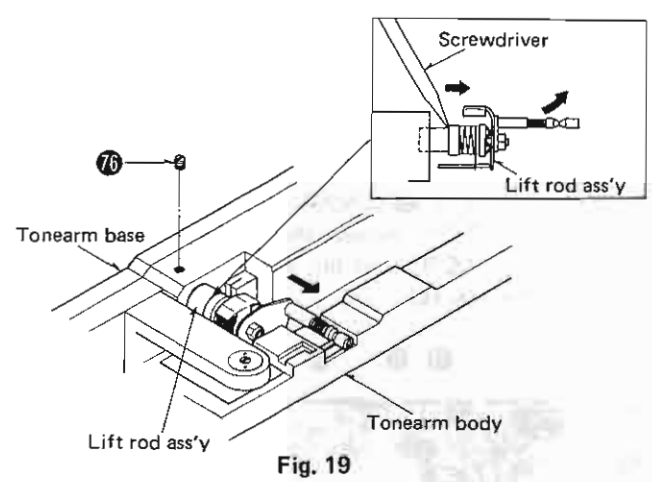

Fig. 18

- **How to remove the lift rod assembly**
 1. Remove the tonearm unit. (Refer to "How to remove the tonearm unit".)
 2. Remove the setscrew 76 of the lift rod assembly. (See Fig. 19)
 3. Press the outer periphery of the lift rod with a screwdriver as shown in Fig. 19.



- **How to set the tonearm drive rope**

If the rope is disengaged or when setting a new rope, follow the procedure given below.

 1. Remove the tonearm drive plate assembly from the upper cabinet. (Refer to "How to remove the logic control P.C.B., arm motor drive P.C.B. and operation P.C.B.")
 2. Remove E-ring 77 and washer 78 of the tonearm drive wheel. (See Fig. 20)
 3. Set the rope over the arm drive wheel in order (1 ~ 3) as shown in Fig. 21.

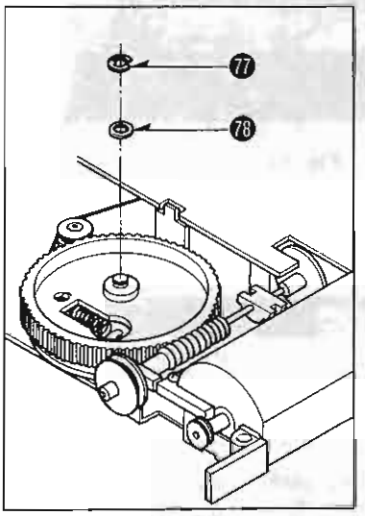

Fig. 20

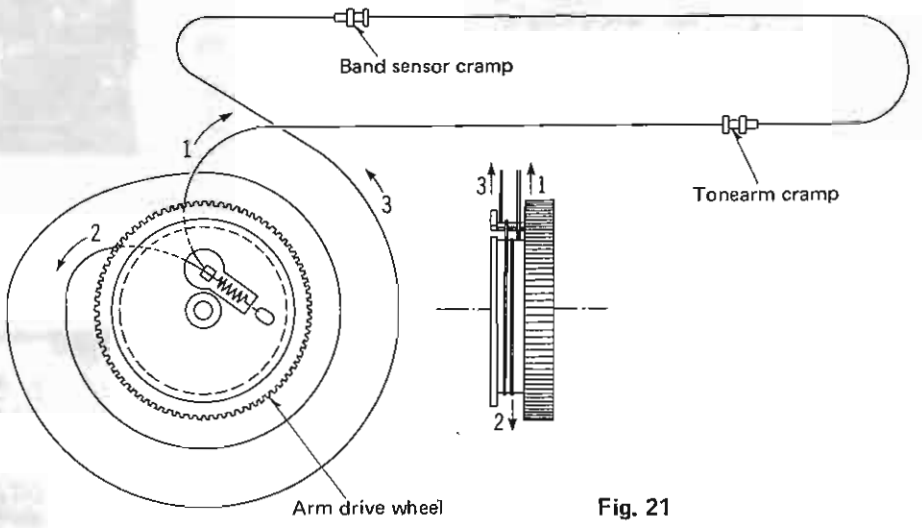

Fig. 21

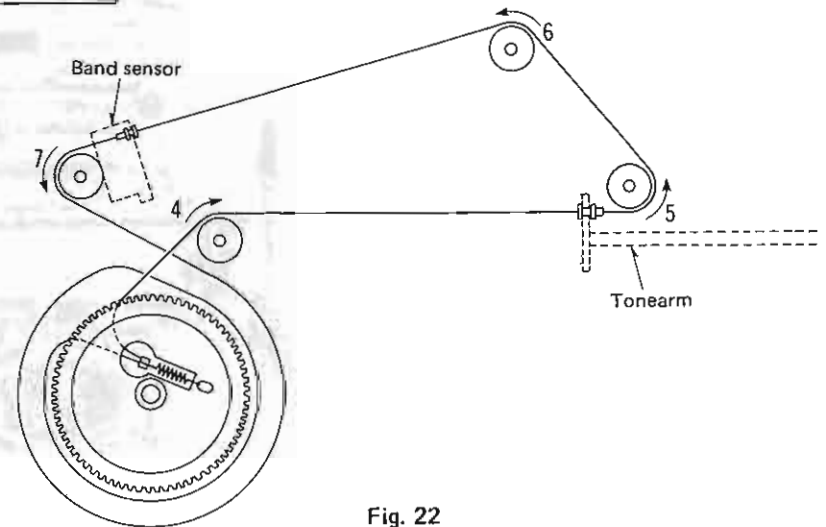

Fig. 22

4. Holding the rope set on the arm drive wheel, set it over the drive wheels (4 ~ 7) in order as shown in Fig. 22.
5. Slide the tonearm and the record band sensor; secure the parts to the rope cramp. (See Fig. 21)
6. Turn the worm gear by hand to make sure that the tonearm and the record band sensor move smoothly.
7. Fit the arm drive wheel with E-ring 77 and washer 78.

■ **DESCRIPTION OF CONNECTOR**

Two types of connectors are used for this unit: one is directly soldered to the printed circuit board, and the other is insertion type. The insertion type is represented by "CN", while the direct soldering type is by "BT". (See Fig. 23)
Note: Soldered connectors (indicated by BT) cannot be pulled out.

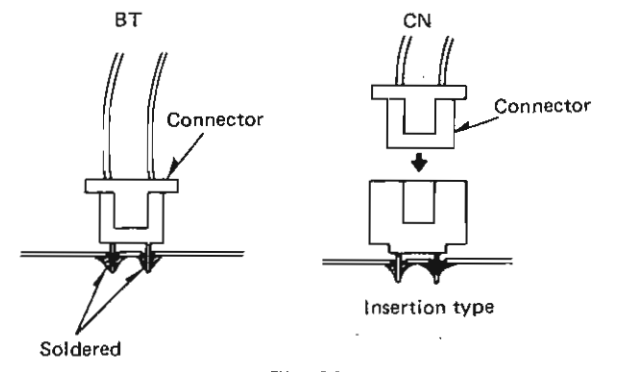

Fig. 23

■ **MEASUREMENTS AND ADJUSTMENTS** English

• **Adjustment of auto start position**

The auto start position has been adjusted according to the record size specified by JIS (Japan Industrial Standards). If the stylus fails to operate at the specified position on the record disc, adjust it according to the following procedure.
 * When adjusting, be sure to use a 30cm record disc.

1. Remove the dust cover. (Refer to "How to remove the dust cover".)
2. Make sure that the tonearm is at the start position (on the rest).
3. Adjust by turning the auto start position adjusting screw. (See Fig. 24)
 If the position is deflected inside. turn the screw clockwise.
 If the position is deflected outside. turn the screw counterclockwise.

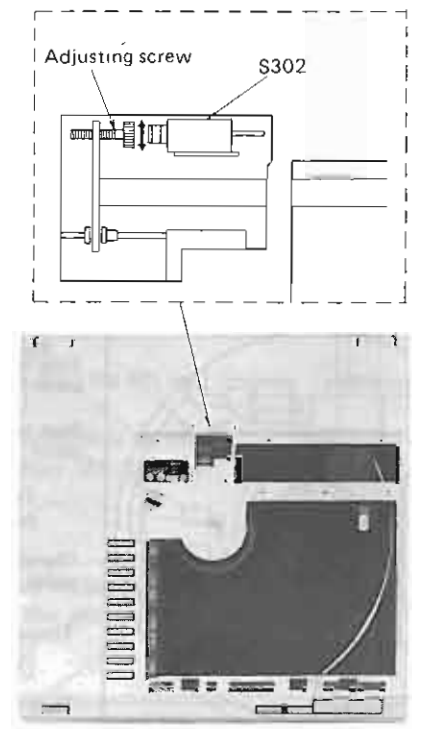

Fig. 24

• **Adjustment of stylus pressure**

Stylus pressure is normally set to 1.25 grams but may be raised or lowered by ± 0.25 grams. It may be necessary to increase stylus pressure when playing records cut at high levels, or when room temperature is low, or when the unit easily picks up external vibrations. This will help prevent distortion and groove-skipping. In such cases, turn the screw clockwise (+) so that dial scale shows the desired stylus pressure, as indicated in the illustration. (See Fig. 25)

Note: Do not turn the stylus-pressure adjustment screw further than the set limits (1.5 g ~ 1.0 g).

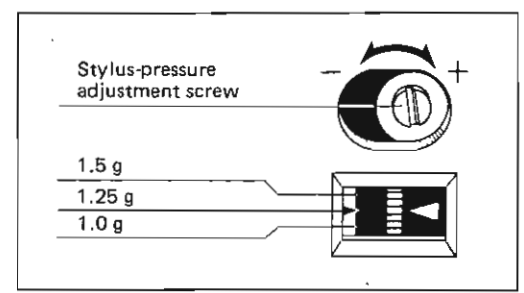

Fig. 25

• Adjustment of stylus cue-down position

Stylus cue-down position for programmed play has been correctly aligned at the factory. However, should realignment become necessary, follow the directions below. The adjustment screw is above the shutter switch (on the underside of the cabinet top).

- During programmed play, if the stylus tends to come down too far out, turn the screw clockwise. (Fig. 26)
- If it comes down too far in, turn the screw counter-clockwise. Adjustment is only possible for bands 2 through 10. The first bands position cannot be changed.
- * For the adjustment of the stylus cue-down position for the 1st band, adjust the auto start position.

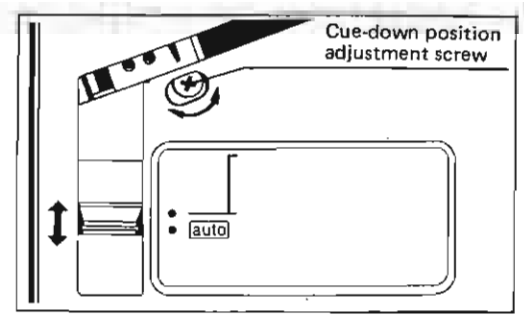

Fig. 26

• Adjustment points

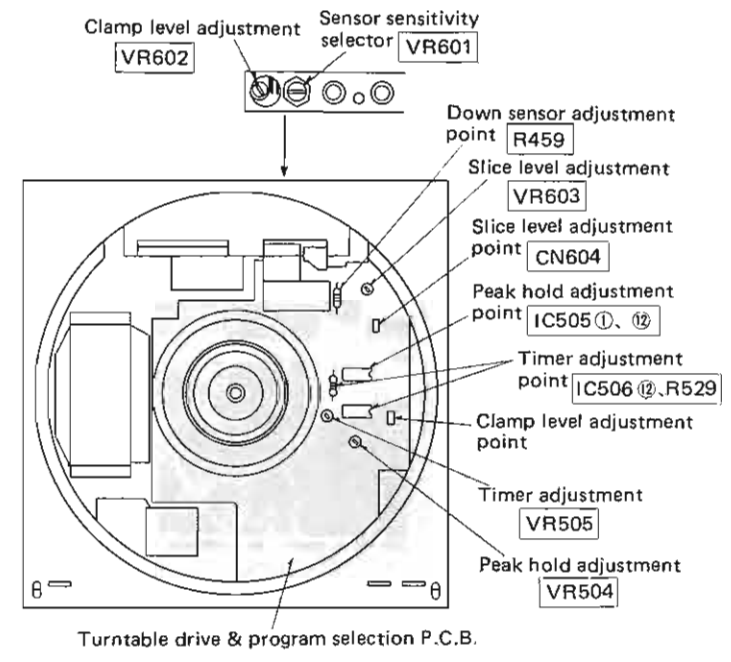

Fig. 27

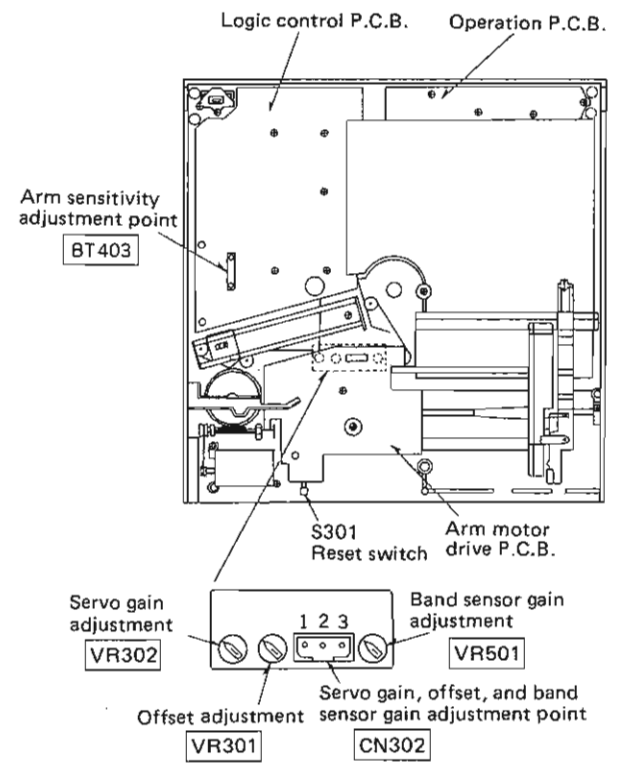

Fig. 28

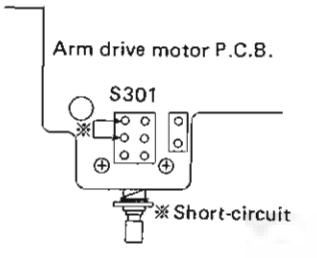

Fig. 29

• Adjustment of tonearm unit

- Tools used**
1. DC electronic voltmeter
 2. 1mm pitch record
 3. Screwdriver (small)
 4. Hexagon wrench (M1.5)
 5. Adjusting screwdriver

- Setting**
1. Remove the dust cover and top cover. (Refer to "Disassembly Instructions".)
 2. Short-circuit the reset switch (S301), (See Fig. 29)
 3. Open the upper cabinet and make sure that the tonearm can be operated by switch.

Step	Item	Adjustment procedure
1	Adjustment of tonearm offset angle. [Repair of tonearm unit; assembly and replacement of lift rod.]	<ol style="list-style-type: none"> ① Put on the record and push the start button to move the arm inward and turn off the power switch. ② Open the upper cabinet and make sure that tonearm center matches the V groove of the lift rod. (See Fig. A) ③ Make sure that the tonearm is parallel with the arm base. (Check the spaces (A) and (B) in Fig. A.) ④ If the parallelism is not obtained adjust it by turning the offset angle adjusting screw. <p>Fig. A</p>
2	Adjustment of arm lift height. [Repair of tonearm unit; assembly and replacement of lift rod.]	<ol style="list-style-type: none"> ① Open the upper cabinet. Move the tonearm by pushing the start button. ② Lower the tonearm by pushing the cueing button. ③ Make sure that the distance between arm and guide rail is 8 ~ 9 mm. (See Fig. B) ④ If the distance is wrong, adjust it by turning the lift adjusting hole with a screwdriver. (See Fig. B) <p>Fig. B</p>
3	Sensitivity adjustment of down-sensor. [Repair of down-sensor; assembly and replacement of tonearm unit.]	<ol style="list-style-type: none"> ① Remove the turntable and connect the DC electronic voltmeter the both ends of R459. (See Fig. 27) ② Lock the tonearm by sliding the arm lock. ③ Push the cueing button and make sure that the lift rod moves down. (Only the lift rod descends since the tonearm is locked.) ④ Read the voltage values indicated when the lift rod moves down and up. Down 3.5V or over Up 0.5V or less ⑤ If the DC electronic voltmeter does not indicate these voltage values, adjust it by turning the down-sensor adjusting screw. (See Fig. C) <p>Fig. C</p>
4	Adjustment of tonearm sensitivity. [Repair of arm base unit; replacement of PC402.]	<ol style="list-style-type: none"> ① Connect the DC electronic voltmeter to the terminals ① (+) and ⑨ (-) of BT403 of the logic control P.C.B. (See Fig. 28) ② Push the start button to move the tonearm. ③ Push the cueing button to move the arm down. ④ Read the voltage values indicated when the arm is completely moved in the directions (A) and (B). (See Fig. D) ⑤ Calculate the voltage at the central point from the difference between the voltage values. For example, when the voltage is 7.6V in the direction of (A), and 0.4V in the direction of (B), then the calculation is as follows. $(7.6 - 0.4) \div 2 + 0.4 = 4.0V$ ⑥ Match the arm center with the V groove of the lift rod, and adjust by turning the adjusting screw of the arm base with a hexagon wrench. <p>Fig. D</p>

Step	Item	Adjustment procedure
5	Adjustment of servo gain and offset. [Replacement of VR301, 302, PC402; repair of servo and offset circuit.]	<p>① Connect the DC electronic voltmeter to the terminals ① and ② of connector (CN301) in the adjusting hold. (See Fig. E)</p> <p>② Push the cueing button to move the arm down.</p> <p>③ Completely turn VR301 clockwise, and then turn VR302 so that the DC electronic voltmeter indicates 0.72V. (See Fig. E) Servo gain adjustment.</p> <p>④ Put a 1 mm pitch record on the turntable and play it.</p> <p>⑤ Turn VR301 so that the DC electronic voltmeter indicates 0.6V. (See Fig. E) Offset adjustment.</p>

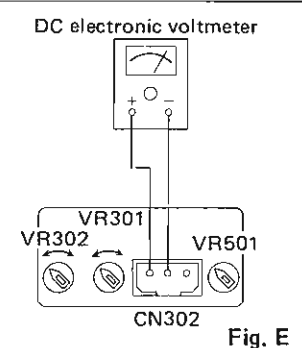

Fig. E

• Adjustment of program selection circuit

- Tools used**
- Oscilloscope (two channel type)
 - Adjusting screwdriver
 - 30 cm record
 - DC electronic voltmeter

- Setting**
- Remove the dust cover. (Refer to "Disassembly instructions".)
 - Short-circuit reset switch (S301).
- * For the adjustment of the program selection circuit, follow the procedure in the table below.

Step	Item	Adjusting procedure
1	Band sensor gain adjustment. [Repair of program selection circuit; replacement of band sensor and VR501.]	<p>① Connect the oscilloscope to CN302 [terminals ②, ③] in the access hole of the upper cabinet. (See Fig. F)</p> <p>② Place the record on the turntable and move the tonearm toward the center of the disc where there is no sound groove.</p> <p>③ Stop the turntable by hand and adjust VR501 so that the output voltage is $1.7 \pm 0.1V$. (See Fig. G)</p> <p>Note: Be sure to stop the turntable because the output waveform changes if the turntable is rotating.</p>

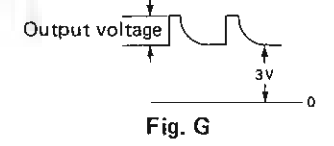

Fig. G

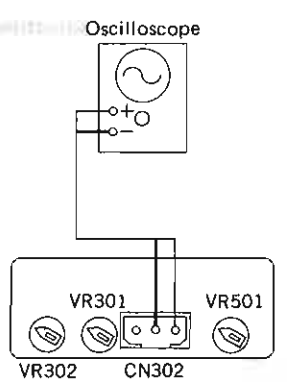

Fig. F

2	Peak hold adjustment [Repair of program selection circuit; replacement of VR504, IC506.]	<p>① Remove the turntable. (See "Disassembly Procedure".)</p> <p>② Connect CH1 of the oscilloscope (two channel type) to IC505 terminal ①, and CH2 to terminal ②. (See Fig. 27)</p> <p>③ Bring the no-sound groove (around the disc center) of the record disc close to the band sensor of the upper cabinet and secure it with tape. (See Fig. H)</p> <p>④ Adjust VR504 so that the peak wave phase of CH2 is as shown in Fig. I. The output of CH1 varies in peak value depending on the interval between the record disc and sensor or the reflection factor of record surface.</p>
---	---	--

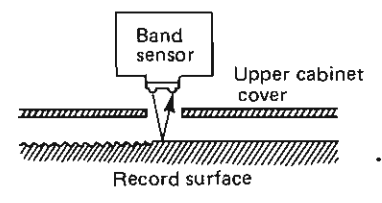

Fig. H

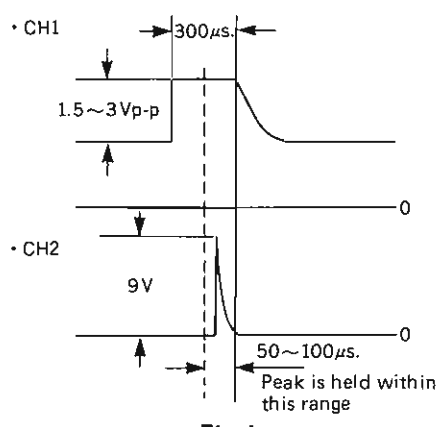

Fig. I

Step	Item	Adjusting procedure
3	Slice level adjustment [Repair of program selection circuit; replacement of VR603.]	<p>① Connect the DC voltmeter to CN604. (See Fig. 27)</p> <p>② Lock the tonearm and push the cueing button to lower the lift. (Then, make sure the illuminating lamp goes out.)</p> <p>③ Adjust VR603 so that the voltage value is $0.5 \pm 0.02V$.</p>
4	Clamp level adjustment [Repair of program selection circuit; replacement of VR602.]	<p>① Connect the DC electronic voltmeter to CN603 [terminals ①, ③]. (See Fig. 27)</p> <p>② Lock the tonearm and push the cueing button to lower the lift. (Then make sure the illuminating lamp goes out.)</p> <p>③ Adjust VR602 so that the voltage value is 1.0 to 1.3V.</p>
5	Timer adjustment [Replacement of IC506, VR505.]	<p>① Remove the turntable, then connect an oscilloscope to No. ⑩ terminal of IC506 at the pointer intermediately by R529. (See Fig. 27 and J)</p> <p>② Short circuit the 9V of No. ⑫ terminal of IC506 with No. ⑬ terminal, supply trigger pulse as the input, then adjust VR505 so as the output pulse width at R529 becomes 100ms.</p>

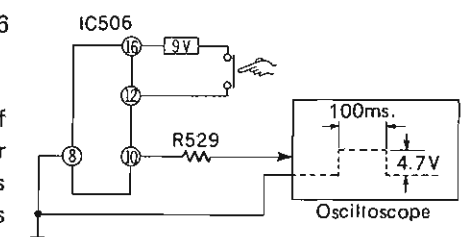

Fig. J

6	Descend-at-blank position adjustment [Repair of program selection circuit; replacement of band sensor.]	<p>① After completing the adjustment above, let the tonearm descend between the 1st and 2nd bands. (To play the program.)</p> <p>② If the position is incorrect, adjust it according to the same procedure as in "Adjustment of stylus cue-down position".</p>
---	--	--

■ SYMPTOMS DUE TO DEFECTIVE ADJUSTMENTS OF THE PROGRAM SELECTION CIRCUIT

- Band sensor gain adjustment**
 - Gain is insufficient:
 - * Since turntable detection at rest position is impossible, 17 cm and 25 cm records are detected as 30 cm record.
 - * Blank between bands is skipped.
 - Gain is excessive:
 - * A 30 cm record is not detected as 30 cm record but as 25 cm or 17 cm record.
 - * In this case, the stylus is liable to drop into sound groove.
- Peak hold adjustment**
 - * Record size cannot be detected.
 - * Blank between bands cannot be detected.
- Slice level adjustment and clamp level adjustment**
 - Level is too high:
 - * Blank between bands is skipped.
 - * Stylus is liable to drop into sound groove.
- Timer adjustment**
 - Time is too long:
 - * It is impossible to detect bands whose width is about 2 mm.
 - Time is too short:
 - * Blanks in a band are detected by mistake as blanks between bands, resulting in faulty detection.

MESSUNGEN UND JUSTIERUNGEN Deutsch

Justierung der Auto-Start-Position

Die Auto-Start-Position wurde in Übereinstimmung mit der durch die JIS (Japanische Industriennorm) vorgeschriebenen Plattengröße justiert. Wenn die Abtastnadel nicht an der Korrekten Stelle auf die Platte abgesenkt wird, ist auf folgende Weise zu korrigieren.

*Für diese Justierung muß unbedingt eine 30cm-Platte verwendet werden.

- 1. Die Staubabdeckung abnehmen. (Siehe "Entfernen der Staubabdeckung".)

- 2. Überprüfen, daß der Tonarm in der Start-Position ist (auf der Ablage).

- 3. Durch Drehen der Auto-Start-Position-Justierschraube justieren. (Siehe Abb. 24)

Falls die Start-Position zu weit innen ist die Schraube im Uhrzeigersinn drehen.

Falls die Start-Position zu weit außen ist die Schraube entgegen dem Uhrzeigersinn drehen.

Justieren Sie die Auflagekraft in den folgenden Fällen

Die normale Auflagekraft beträgt 1,25 g, doch kann sie um ± 0,25 g gesenkt oder erhöht werden.

Es könnte notwendig sein, die Auflagekraft zu erhöhen, wenn Platten abgespielt werden, die bei hohem Pegel geschnitten wurden, wenn die Raumtemperatur tief ist, oder wenn der Plattenspieler externer Vibration ausgesetzt ist. Dies hilft dabei, Verzerrung und Überspringen der Rillen zu vermeiden.

Drehen Sie die Schraube in einem solchen Fall im Uhrzeigersinn (+), bis die Skala die gewünschte Auflagekraft anzeigt, wie in der Skizze gezeigt. (Abb. 25)

Anmerkung:

Drehen Sie die Auflagekraft-Justierschraube nie weiter, als bis zu den Begrenzungen (1,5 g ~ 1,0 g).

Justierung der Nadel-Absenkposition

Die Nadelabsenkposition für das programmierte Abspielen wurde werkseitig korrekt justiert. Falls trotzdem eine Neujustierung nötig wird, auf folgende Weise vorgehen.

Die Justierschraube befindet sich über dem Blendenschalter (an der Unterseite des Gehäuseoberteils).

*Wenn die Abtastnadel beim programmierten Abspielen generell zu weit außen abgesenkt wird, die Schraube im Uhrzeigersinn drehen. (Abb. 26)

*Wenn die Abtastnadel zu weit innen abgesenkt wird, die Schraube entgegen dem Uhrzeigersinn drehen. Die Justierung ist nur möglich für die Musikstücke 2 bis 10. Die Position des ersten Musikstückes kann mit dieser Schraube nicht justiert werden.

*Für die Justierung der Nadelabsenkposition für das erste Musikstück ist die Auto-Start-Position zu justieren.

Justierung der Tonarmeinheit

Benötigte Werkzeuge und Instrumente

- 1. Elektronisches Gleichstrom-Voltmeter
2. Platte mit 1 mm-Rillenabstand
3. Schraubenzieher (klein)
4. Sechskantschlüssel (M1.5)
5. Justierschraubenzieher

Zustand des Gerätes

- 1. Die Staubabdeckung und die Oberabdeckung entfernen. (Siehe "Anleitung für die Zerlegung".)
2. Den Deckelschalter (S301) kurzschließen. (Siehe Abb. 29)
3. Das Gehäuseoberteil öffnen und überprüfen, daß der Tonarm funktioniert, wenn die Start-Taste gedrückt wird.

Table with 3 columns: Schritt, Einstell-Gegenstand, Justiermethode. It contains 5 rows of adjustment steps for the SL-15 turntable, including steps for tonearm friction angle, tonearm lift height, absence sensor sensitivity, tonearm sensitivity, and servo amplifier/balance.

EXPLODED VIEW.....Main Cabinet

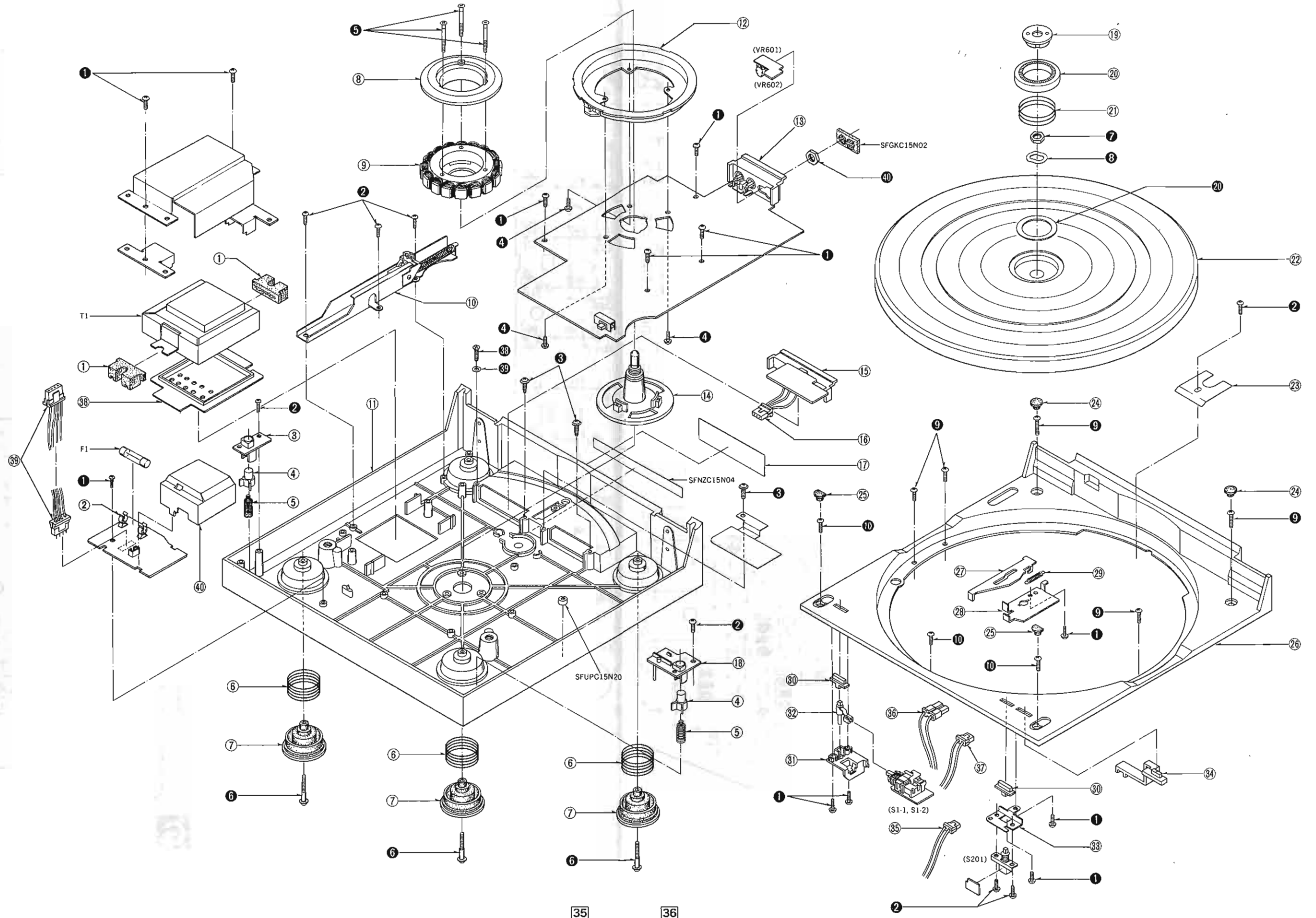

Ref. No.	Part No.	Part Name & Description
SCREWS, WASHERS and NUTS		
1	XTV3+8BFN	Screw, Tapping, \oplus 3 x 8
2	XTN3+6B	Screw, Tapping, \oplus 3 x 6
3	SFPEV17202	Screw
4	XTN26+6B	Screw, Tapping, \oplus 2.6 x 6
5	SFXGC10-03	Screw
6	SFXGQ20-01	Screw, Insulator
7	XNS12	Nut, ϕ 12
8	SFXWC10-01	Washer
9	XTN3+20BFZ	Screw, Tapping, \oplus 3 x 20
10	XTN3+10BFZ	Screw, Tapping, \oplus 3 x 10
11	SFXGC10-05	Screw
12	SFXGC10-02	Screw
13	XSS26+5BN	Screw, Tapping, \oplus 2.6 x 5
14	XUC2FT	Washer
15	XUC3FT	Washer
16	SFXW551D2	Washer
17	XYN23+C108N	Screw, Tapping, \oplus 2.3 x 10
18	XTS26+6JFZ	Screw, Tapping, \oplus 2.6 x 6
19	XTN3+8B	Screw, Tapping, \oplus 3 x 8
20	SFXWC10-05	Washer
21	XYN3+C6FZ	Screw, Tapping, \oplus 3 x 6
22	SFXWC10-04	Washer
23	XTN3+5J	Screw, Tapping, \oplus 3 x 5
24	XTN3+8BFZ	Screw, Tapping, \oplus 3 x 8
25	XTB3+8JFX	Screw, Tapping, \oplus 3 x 8
26	SFPEV00701	Screw Cartridge
27	XYN2+C4FZ	Screw, Tapping, \oplus 2 x 4
28	XTN23+4JFZ	Screw, Tapping, \oplus 2.3 x 4
29	SFPTN00702	Screw
30	XWC3B	Washer, ϕ 3
31	XNS3+6S	Screw, Tapping, \oplus 3 x 6
32	XXE3D4FZS	Screw, Tapping, \oplus 3 x 4
33	XTN23+6BFZ	Screw, Tapping, \oplus 2.3 x 6
34	XTW3+6J	Screw, Tapping, \oplus 3 x 6
35	XTN3+25JFZ	Screw, Tapping, \oplus 3 x 25
36	XTV3+6BFN	Screw, Tapping, \oplus 3 x 6

Ref. No.	Part No.	Part Name & Description
37	XTN3+12B	Screw, Tapping, \oplus 3 x 12
38	XTS3+8BFZ	Screw, Tapping, \oplus 3 x 8
39	SFXWC10-06	Washer
40	XNG7E	Nut, ϕ 7
41	SFXGC10-06	Screw
ACCESSORIES		
A1 [E] only	SFNUC15S01	Instructions Book, Printed Matter
A1 [EK] only	SFNUC15G01	Instructions Book, Printed Matter
A1	SFNUC15X01	Instructions Book, Printed Matter
A2	SFCZB30001	Brush
A3	SFWTC07-01	Screw, Driver
A4	SFCFB10101	Screw, Driver
A5 [XA], [XM]	QFC1103	AC Cord
A5 [XL] only	RJA26Z	AC Cord
A5	RJA20Z	AC Cord
A5 [EK] only	RJA43Z	AC Cord
A6	SFDHC10-02	Phono Cord
A7	SFNZC15X05	Caution Sheet
A8 [XA], [XL]	SFKD119118	2 Pin Plug
PACKING PARTS		
P1	SFHPC15M01	Carton Box (Silver)
P1 [EF] only	SFHPC15C01	Carton Box (Silver)
P1	SFHPC15M21	Carton Box (Black)
P2	SFHHC15N01	Pad, Unit
P3	SFHSC10-03	Spacer, Corner (A)
P4	SFHSC10-04	Spacer, Corner (B)
P5	SFHSC15N01E	Spacer, Arm
P6	SFHSC10-01	Spacer, Turntable
P7	XSN4D20FYBS	Screw
P8	SFYH45X60	Polyethylene Bag, Unit
P9	SFYF10A30	Polyethylene Bag, Cord
P10	SFYF09A15	Polyethylene Bag, Accessory

EXPLODED VIEW.....Tonearm

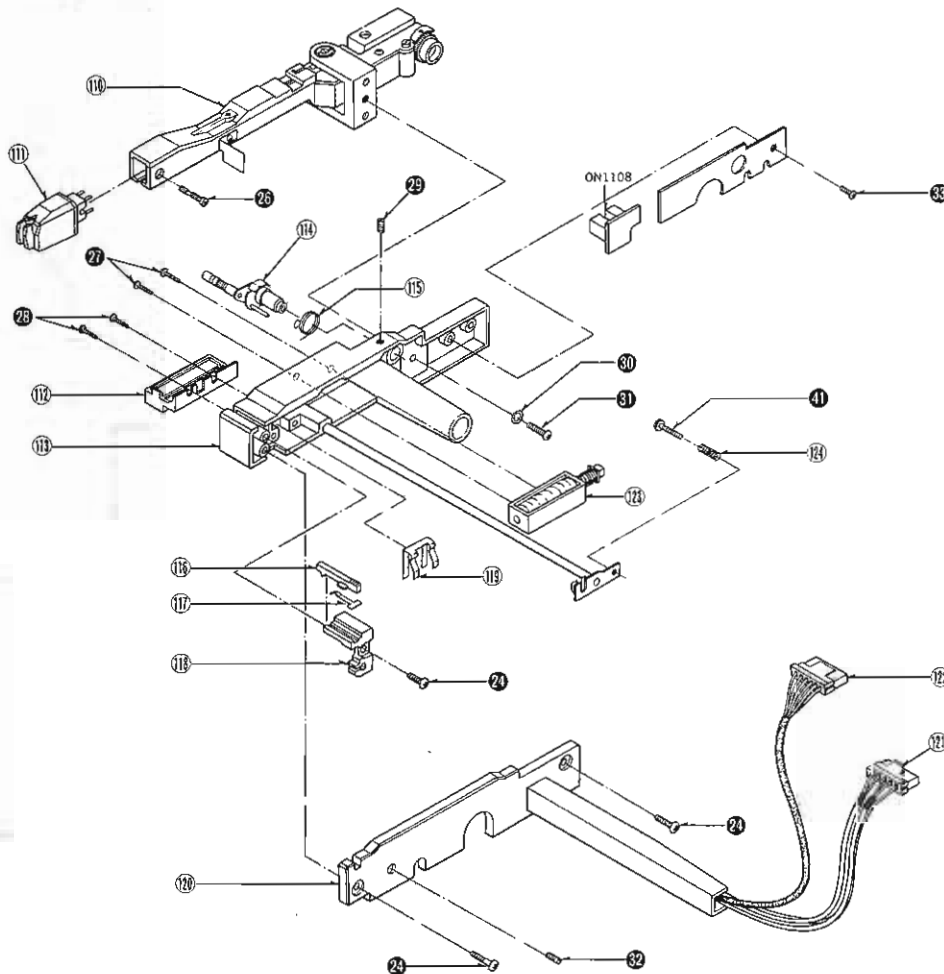

■ SCHEMATIC DIAGRAM (A) (This schematic diagram may be modified at any time with the development of new technology.)

A
B
C
D
E
F

1 2 3 4 5 6 7 8 9

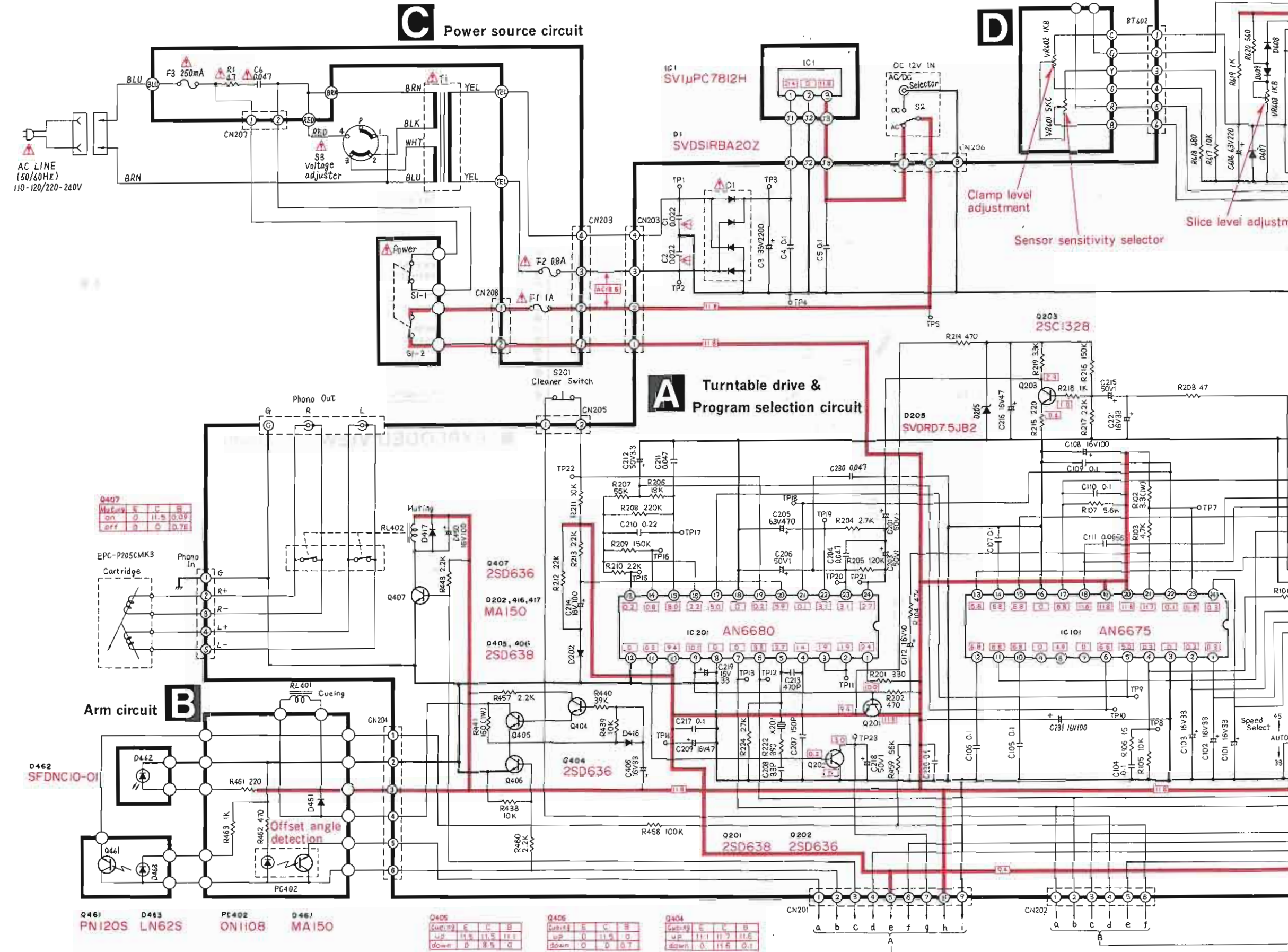

Q407

MuFny	E	C	B
on	0	11.5	0.09
off	3	0	0.7E

Q461

Cueing	E	C	B
up	11.9	11.9	11.1
down	3	3	0

Q463

Cueing	E	C	B
up	0	11.9	0
down	0	0	0.7

PC402

Offset angle	E	C	B
up	0	11.9	0
down	0	0	0.7

Q461 PN120S
D463 LN62S
PC402 ON1108
Q463 MA150

Q405

Cueing	E	C	B
up	11.9	11.9	11.1
down	3	3	0

Q406

Cueing	E	C	B
up	0	11.9	0
down	0	0	0.7

Q404

Cueing	E	C	B
up	11.1	11.7	11.6
down	0	11.9	0.1

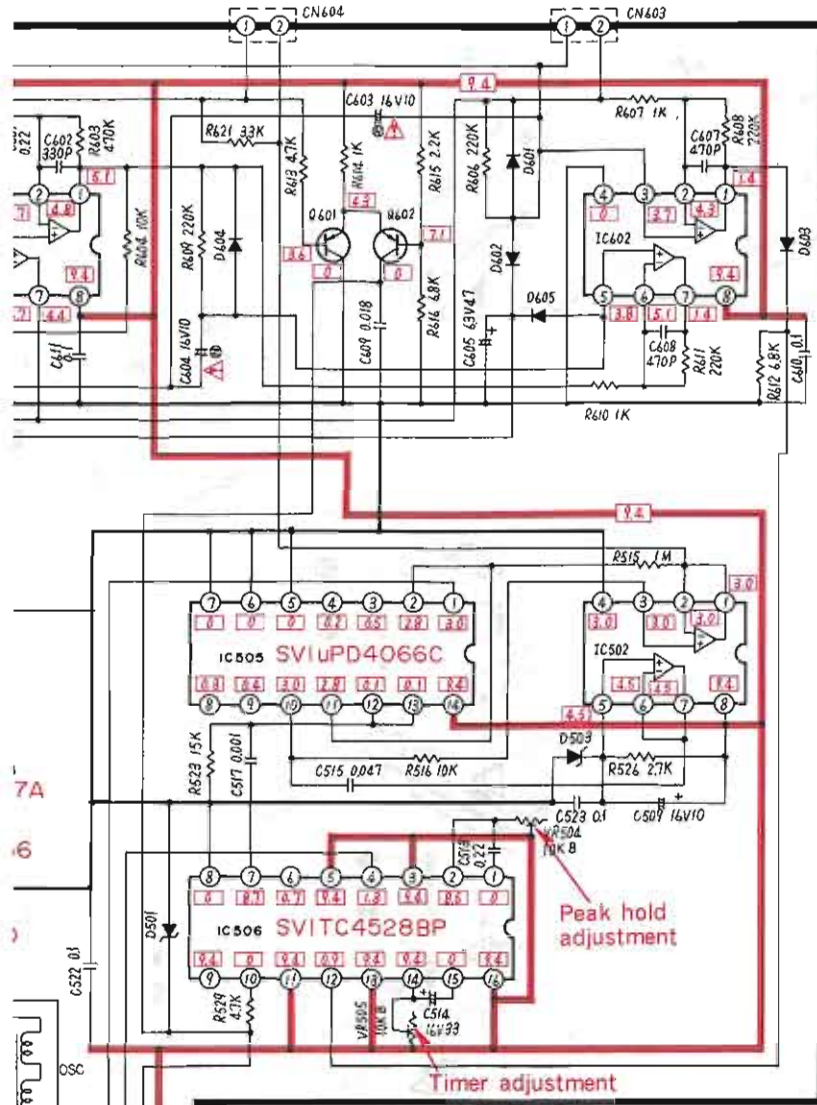

- IC601,602 AN6552
- Q601,602 2SB641
- D601 ~ 605,606,609 MA150
- C607 MA1047A

- IC502 AN6552
- D503 MA1047A

Operation circuit

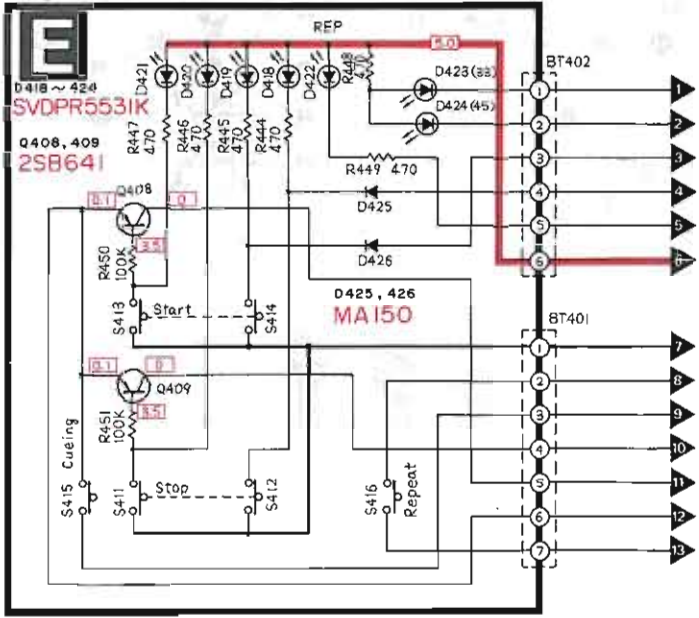

C	B
1.8	0
0	0.7
0	0.7

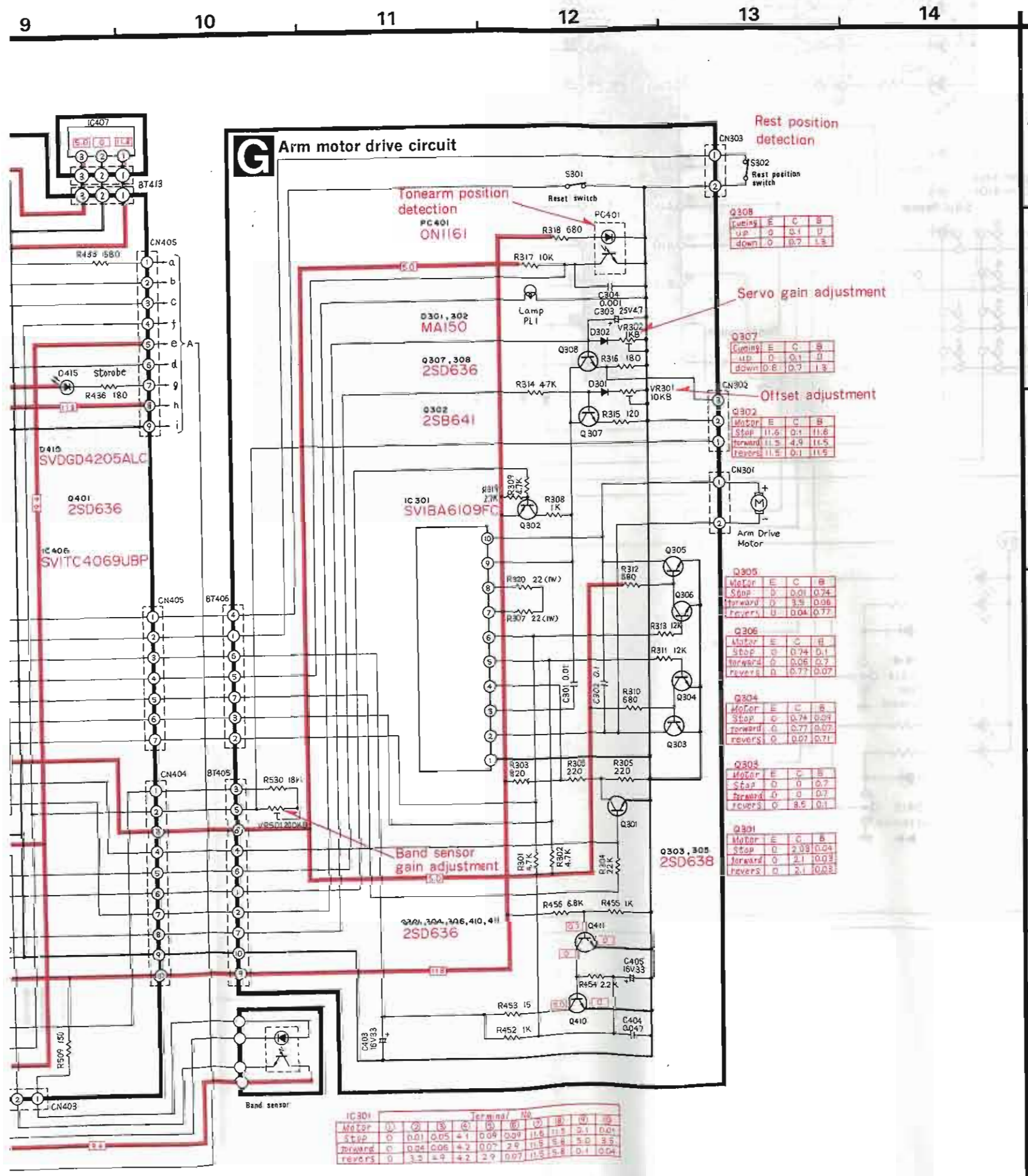

Notes:

- S1-1: Power switch in "on" position. (Primary side)
- S1-2: Power switch in "on" position. (Secondary side)
- S2: AC/DC select switch in "AC" position. (AC/DC input terminal built-in switch - AC priority)
- S3: Voltage adjuster switch in "220V - 240V" position. 110V - 120V → 220V - 240V
- S201: Turntable drive (cleaner) switch in "off" position.
- S202: Speed select switch in "auto" position. (33 → auto → 45)
- S301: Reset switch in "on" position.
- S302: Rest detecting switch in "on" position.
- S401 ~ 410: Program switch (Program key 1 ~ 10) in "off" position. (not push condition)
- S411: Stop/clear switch (▶▶) in "off" position. (not push condition)
- S412: Fast rewind switch (▶▶▶) in "off" position. (not push condition)
- S413: Start switch (◀◀) in "off" position. (not push condition)
- S414: Fast forward switch (◀◀◀) in "off" position. (not push condition)
- S415: Cueing switch in "off" position. (not push condition)
- S416: Repeat switch in "off" position. (not push condition)
- The value in □ is the reference voltage at stop of the turntable, measured by DC electronic circuit tester (high-impedance) on the basis of chassis. Therefore, the measured value may include some error depending on the internal impedance of the DC circuit tester and other conditions.
- ⊕ ⊗ voltage line.
- Important safety Notice: Components identified by ▲ mark have special characteristics important for safety. When replacing any of these components, use only manufacturer's specified parts.

• Terminal guide of transistors, diodes and IC's

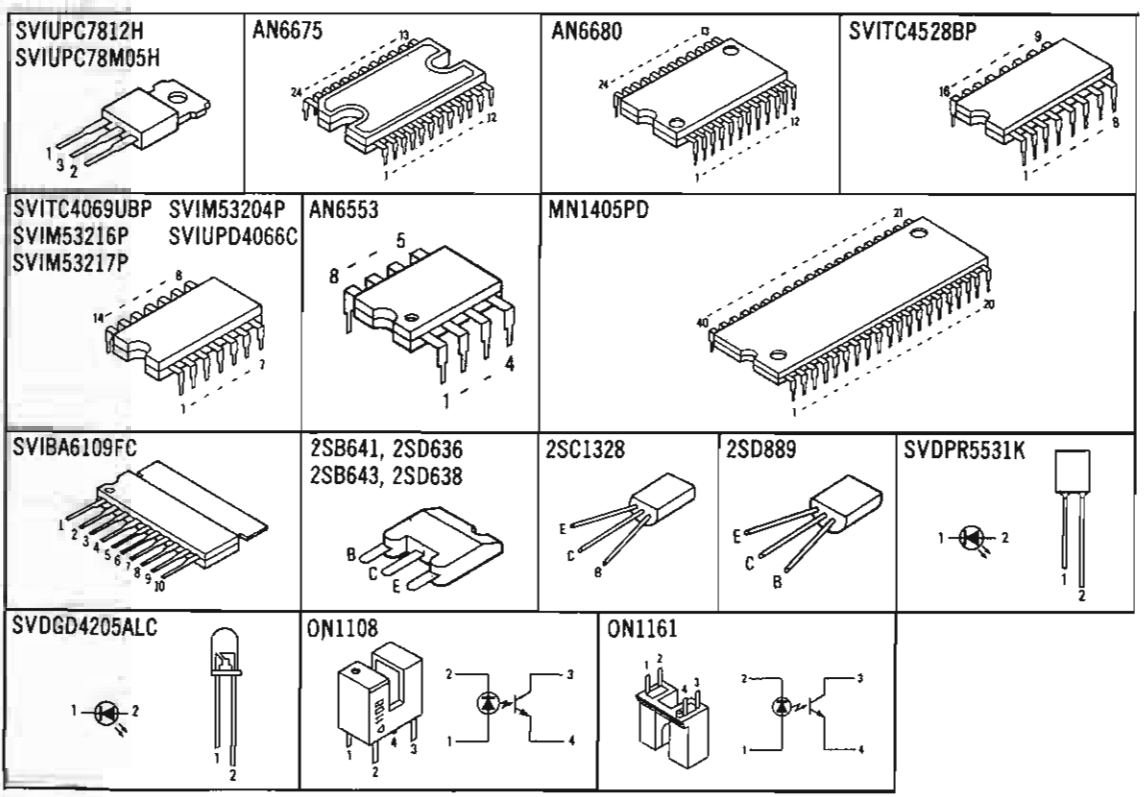

• Block diagram of IC's

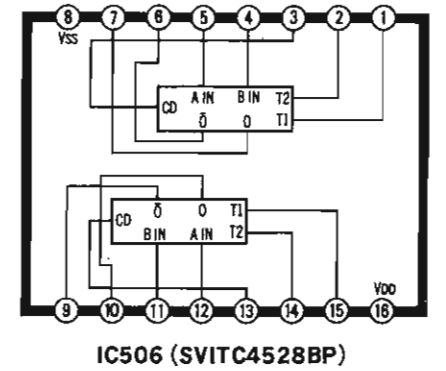
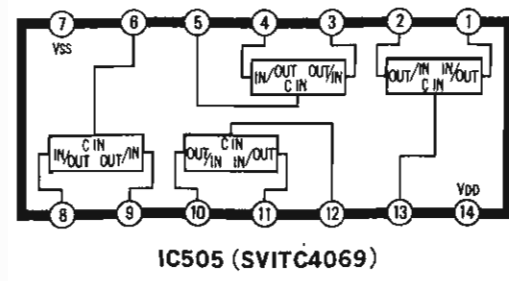

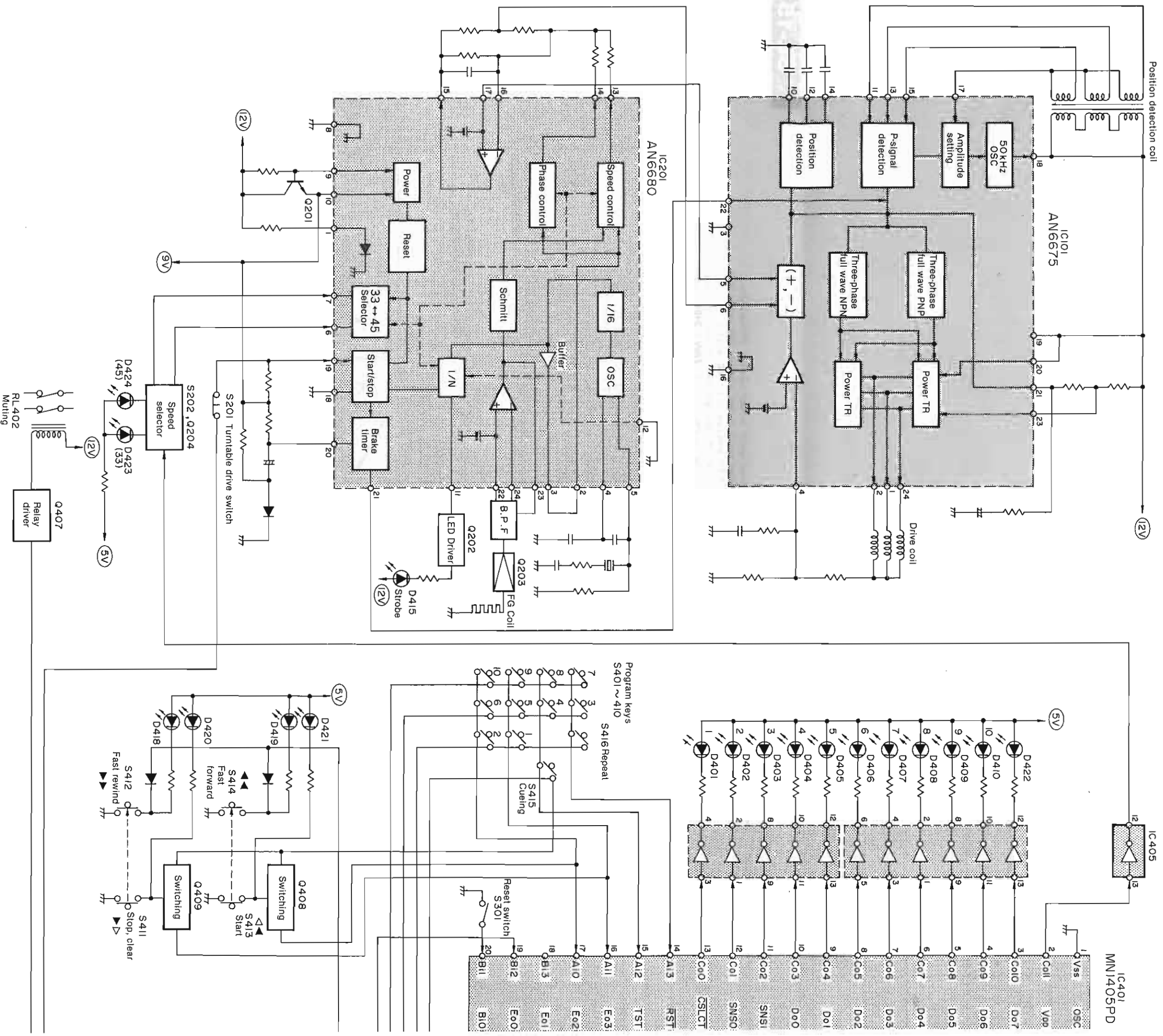

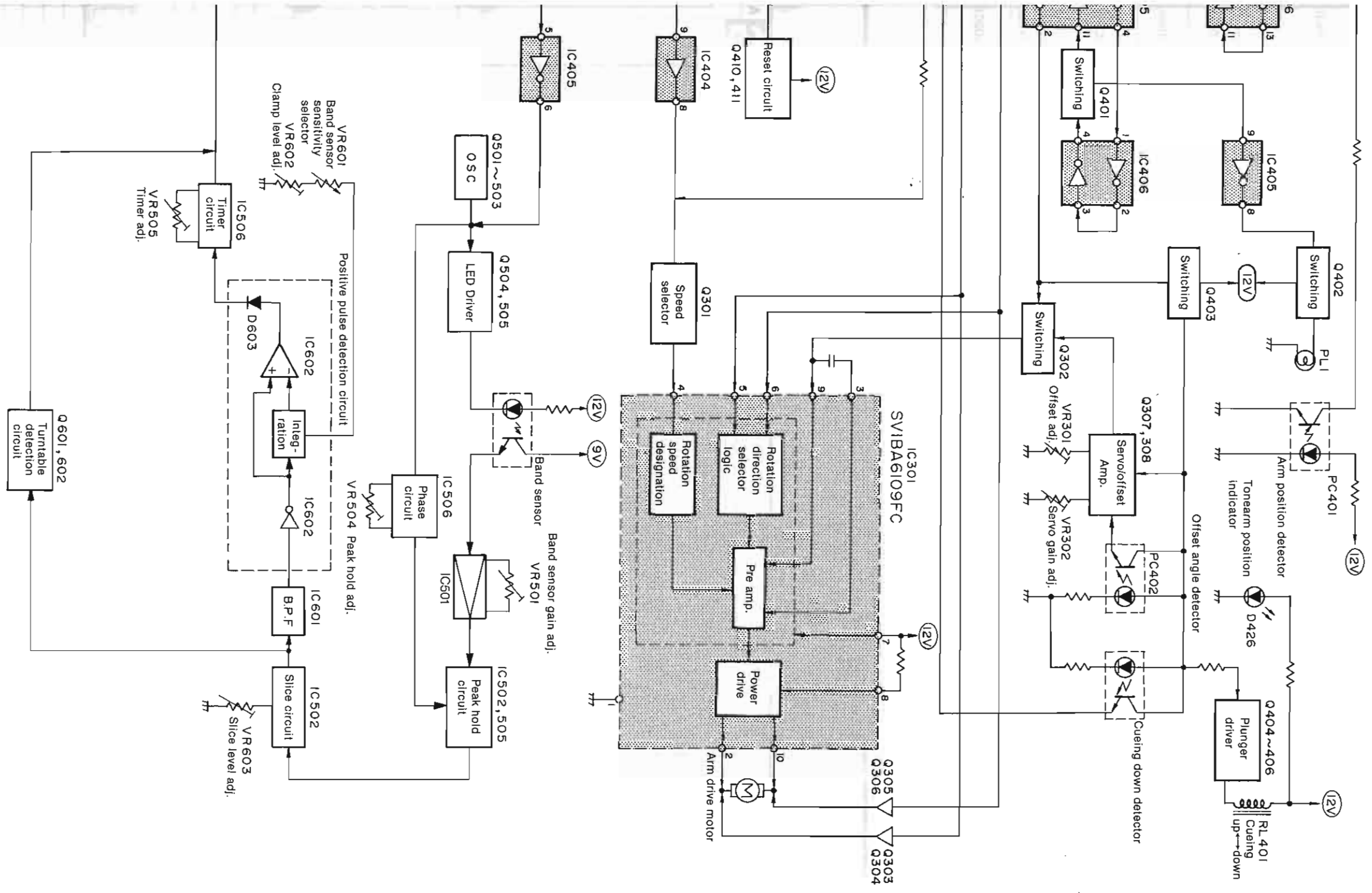

EXPLODED VIEW.....Main Cabinet

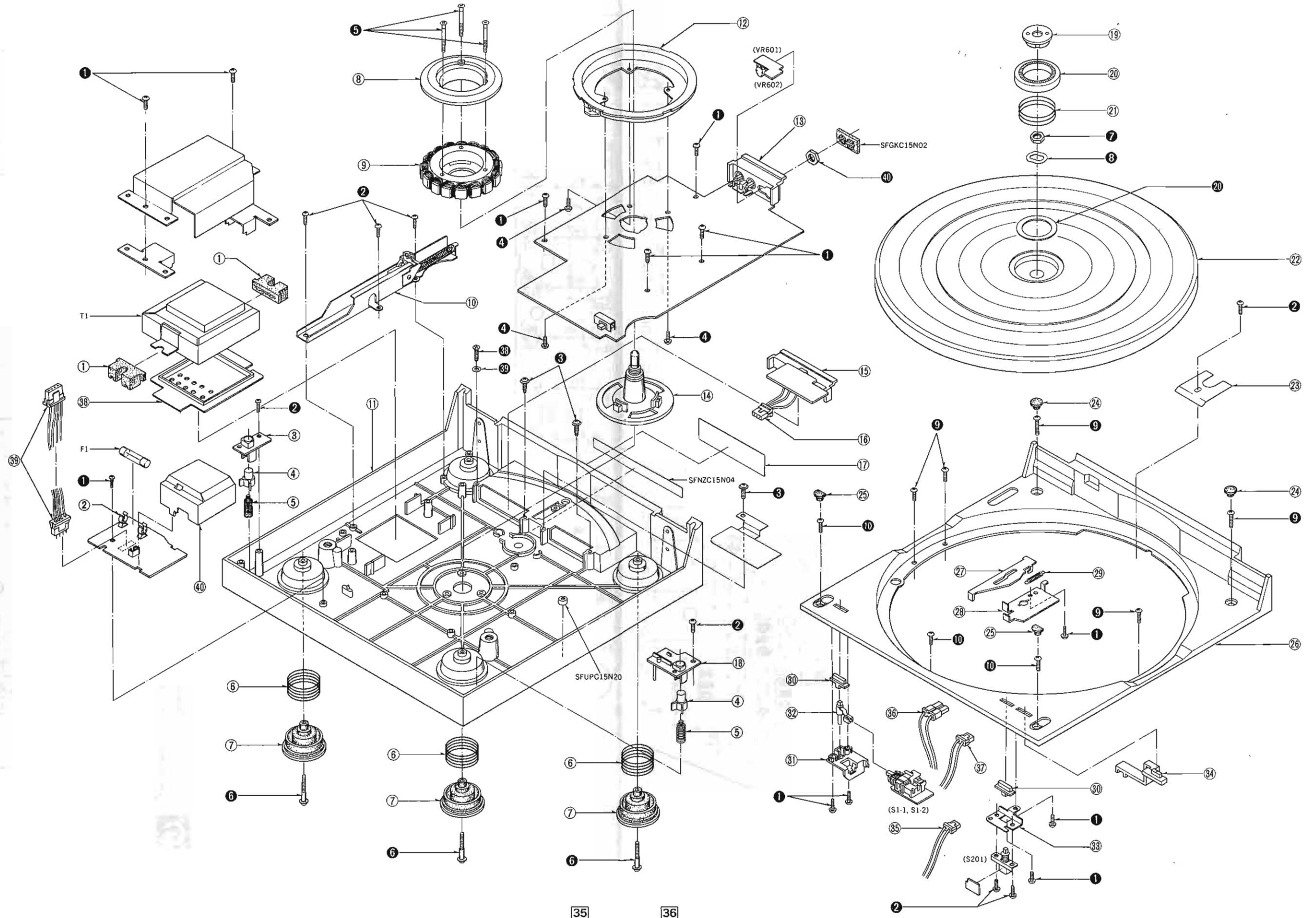

■ EXPLODED VIEW.....Upper Cabinet

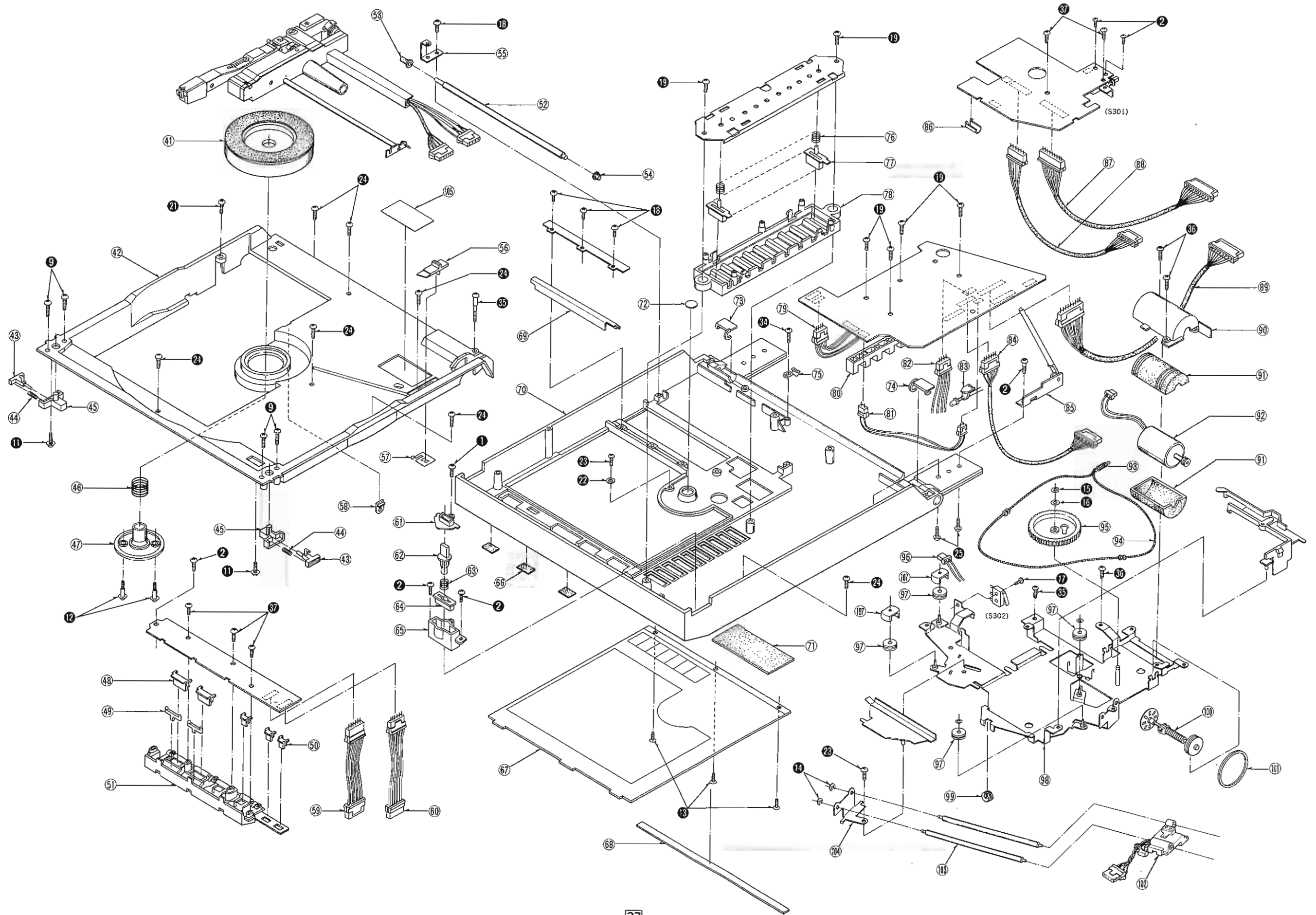

Ref. No.	Part No.	Part Name & Description
SCREWS, WASHERS and NUTS		
1	XTV3+8BFN	Screw, Tapping, \oplus 3 x 8
2	XTN3+6B	Screw, Tapping, \oplus 3 x 6
3	SFPEV17202	Screw
4	XTN26+6B	Screw, Tapping, \oplus 2.6 x 6
5	SFXGC10-03	Screw
6	SFXGQ20-01	Screw, Insulator
7	XNS12	Nut, ϕ 12
8	SFXWC10-01	Washer
9	XTN3+20BFZ	Screw, Tapping, \oplus 3 x 20
10	XTN3+10BFZ	Screw, Tapping, \oplus 3 x 10
11	SFXGC10-05	Screw
12	SFXGC10-02	Screw
13	XSS26+5BN	Screw, Tapping, \oplus 2.6 x 5
14	XUC2FT	Washer
15	XUC3FT	Washer
16	SFXW551D2	Washer
17	XYN23+C108N	Screw, Tapping, \oplus 2.3 x 10
18	XTS26+6JFZ	Screw, Tapping, \oplus 2.6 x 6
19	XTN3+8B	Screw, Tapping, \oplus 3 x 8
20	SFXWC10-05	Washer
21	XYN3+C6FZ	Screw, Tapping, \oplus 3 x 6
22	SFXWC10-04	Washer
23	XTN3+5J	Screw, Tapping, \oplus 3 x 5
24	XTN3+8BFZ	Screw, Tapping, \oplus 3 x 8
25	XTB3+8JFX	Screw, Tapping, \oplus 3 x 8
26	SFPEV00701	Screw Cartridge
27	XYN2+C4FZ	Screw, Tapping, \oplus 2 x 4
28	XTN23+4JFZ	Screw, Tapping, \oplus 2.3 x 4
29	SFPTN00702	Screw
30	XWC3B	Washer, ϕ 3
31	XNS3+6S	Screw, Tapping, \oplus 3 x 6
32	XXE3D4FZS	Screw, Tapping, \oplus 3 x 4
33	XTN23+6BFZ	Screw, Tapping, \oplus 2.3 x 6
34	XTW3+6J	Screw, Tapping, \oplus 3 x 6
35	XTN3+25JFZ	Screw, Tapping, \oplus 3 x 25
36	XTV3+6BFN	Screw, Tapping, \oplus 3 x 6

Ref. No.	Part No.	Part Name & Description
37	XTN3+12B	Screw, Tapping, \oplus 3 x 12
38	XTS3+8BFZ	Screw, Tapping, \oplus 3 x 8
39	SFXWC10-06	Washer
40	XNG7E	Nut, ϕ 7
41	SFXGC10-06	Screw
ACCESSORIES		
A1 [E] only	SFNUC15S01	Instructions Book, Printed Matter
A1 [EK] only	SFNUC15G01	Instructions Book, Printed Matter
A1	SFNUC15X01	Instructions Book, Printed Matter
A2	SFCZB30001	Brush
A3	SFWTC07-01	Screw, Driver
A4	SFCFB10101	Screw, Driver
A5 [XA], [XM]	QFC1103	AC Cord
A5 [XL] only	RJA26Z	AC Cord
A5	RJA20Z	AC Cord
A5 [EK] only	RJA43Z	AC Cord
A6	SFDHC10-02	Phono Cord
A7	SFNZC15X05	Caution Sheet
A8 [XA], [XL]	SFKD119118	2 Pin Plug
PACKING PARTS		
P1	SFHPC15M01	Carton Box (Silver)
P1 [EF] only	SFHPC15C01	Carton Box (Silver)
P1	SFHPC15M21	Carton Box (Black)
P2	SFHHC15N01	Pad, Unit
P3	SFHSC10-03	Spacer, Corner (A)
P4	SFHSC10-04	Spacer, Corner (B)
P5	SFHSC15N01E	Spacer, Arm
P6	SFHSC10-01	Spacer, Turntable
P7	XSN4D20FYBS	Screw
P8	SFYH45X60	Polyethylene Bag, Unit
P9	SFYF10A30	Polyethylene Bag, Cord
P10	SFYF09A15	Polyethylene Bag, Accessory

EXPLODED VIEW.....Tonearm

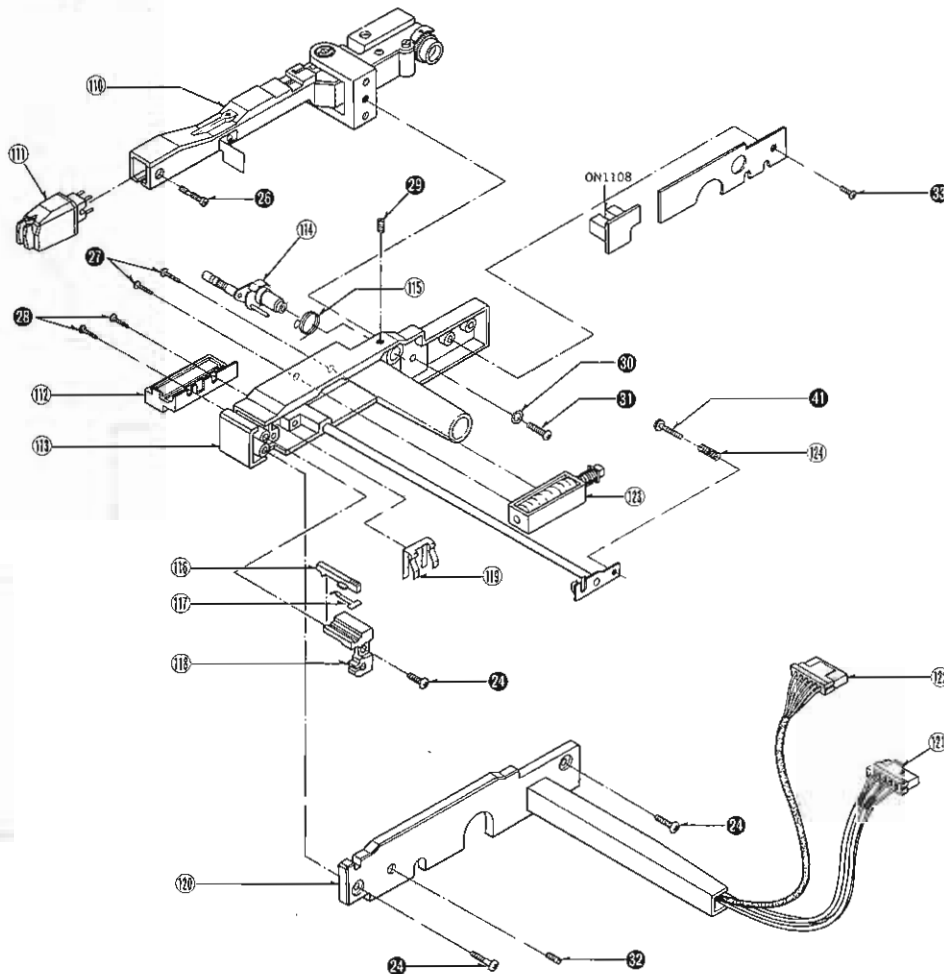

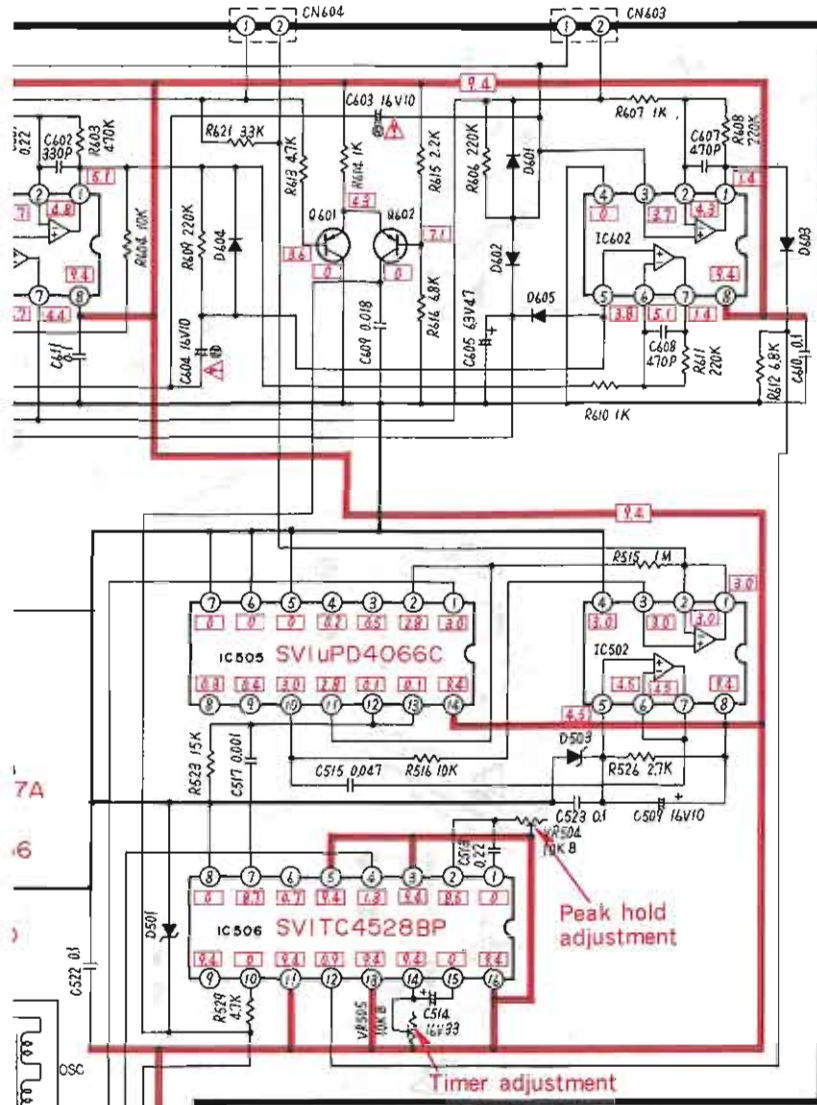

- IC601,602
AN6552
- Q601,602
2SB641
- D601 ~ 605,606,609
MA150
- C607
MA1047A

- IC502
AN6552
- D503
MA1047A

Operation circuit

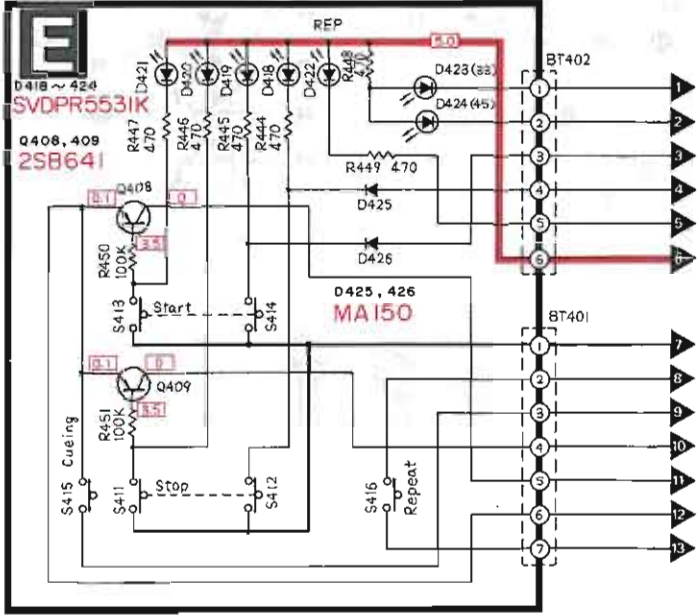

C	B
1.8	0
0	0.7
0	0.7

■ SCHEMATIC DIAGRAM (B) (This schematic diagram may be modified at any time with the development of new technology.)

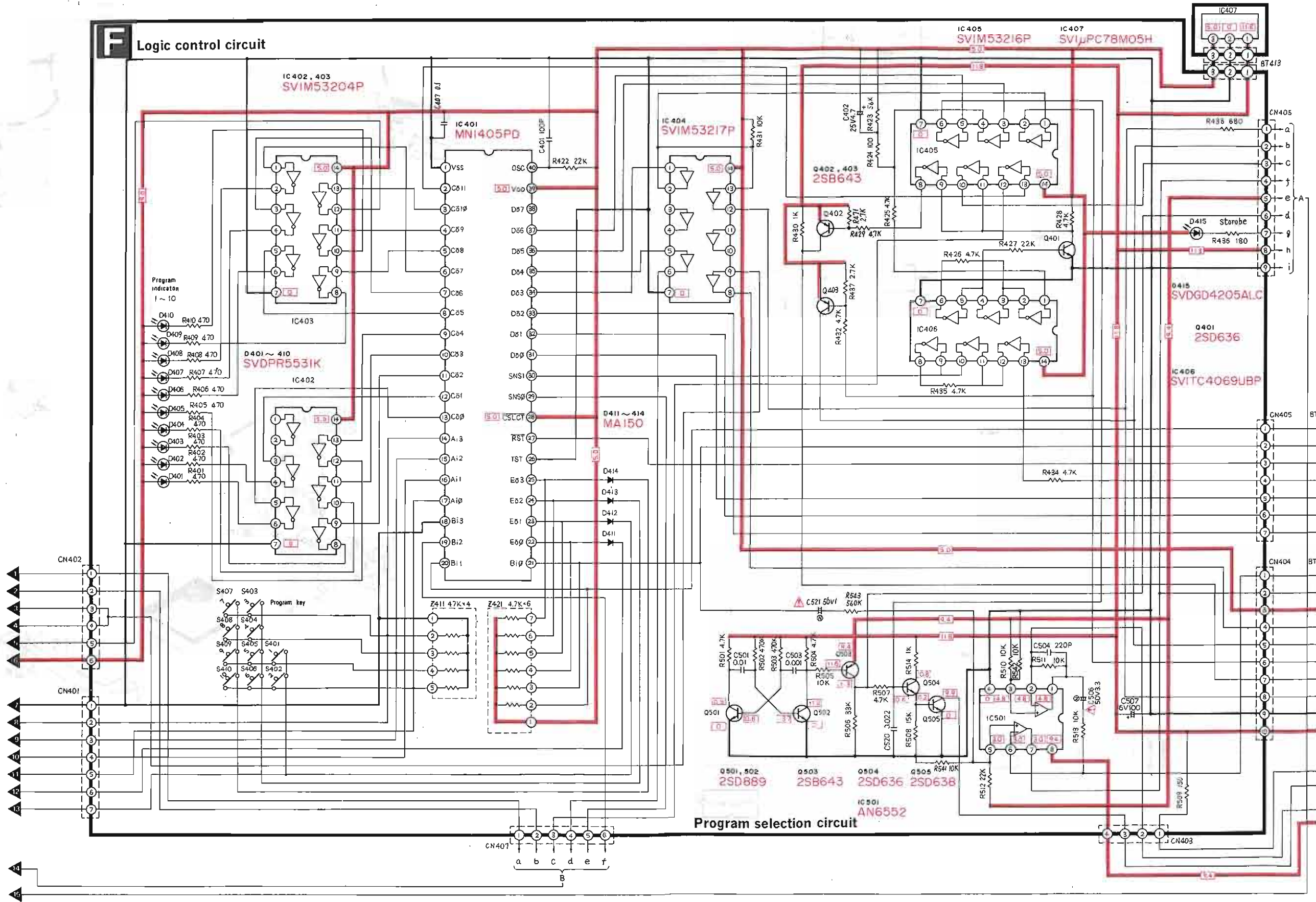

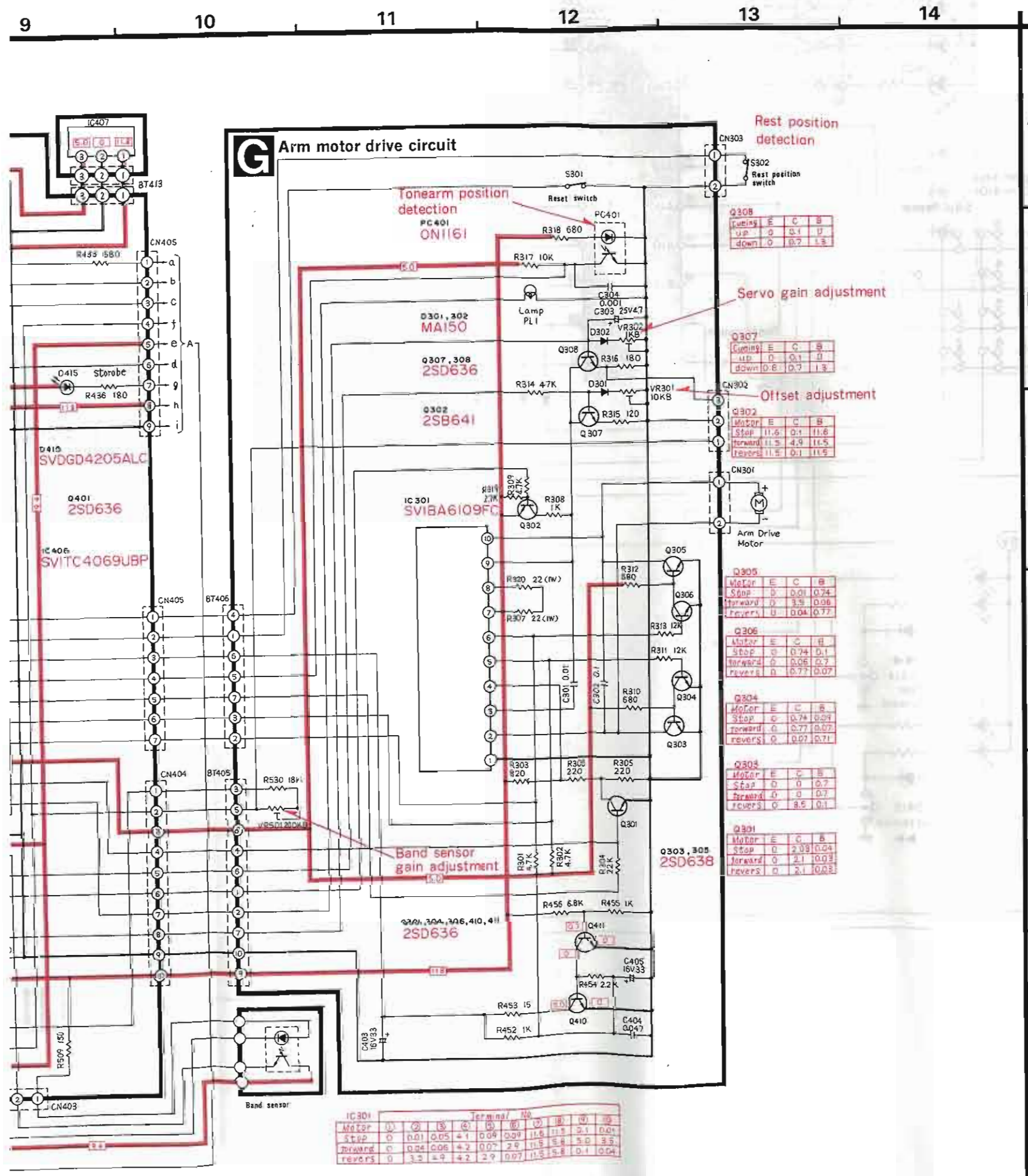

Notes:

- S1-1 : Power switch in "on" position. (Primary side)
 - S1-2 : Power switch in "on" position. (Secondary side)
 - S2 : AC/DC select switch in "AC" position. (AC/DC input terminal built-in switch - AC priority)
 - S3 : Voltage adjuster switch in "220V - 240V" position. 110V - 120V → 220V - 240V
 - S201 : Turntable drive (cleaner) switch in "off" position.
 - S202 : Speed select switch in "auto" position. (33 → auto → 45)
 - S301 : Reset switch in "on" position.
 - S302 : Rest detecting switch in "on" position.
 - S401 ~ 410 : Program switch (Program key 1 ~ 10) in "off" position. (not push condition)
 - S411 : Stop/clear switch (▶▶) in "off" position. (not push condition)
 - S412 : Fast rewind switch (▶▶▶) in "off" position. (not push condition)
 - S413 : Start switch (◀◀) in "off" position. (not push condition)
 - S414 : Fast forward switch (◀◀◀) in "off" position. (not push condition)
 - S415 : Cueing switch in "off" position. (not push condition)
 - S416 : Repeat switch in "off" position. (not push condition)
- The value in is the reference voltage at stop of the turntable, measured by DC electronic circuit tester (high-impedance) on the basis of chassis. Therefore, the measured value may include some error depending on the internal impedance of the DC circuit tester and other conditions.
17. ■ + voltage line.
18. Important safety Notice: Components identified by ▲ mark have special characteristics important for safety. When replacing any of these components, use only manufacturer's specified parts.

• Terminal guide of transistors, diodes and IC's

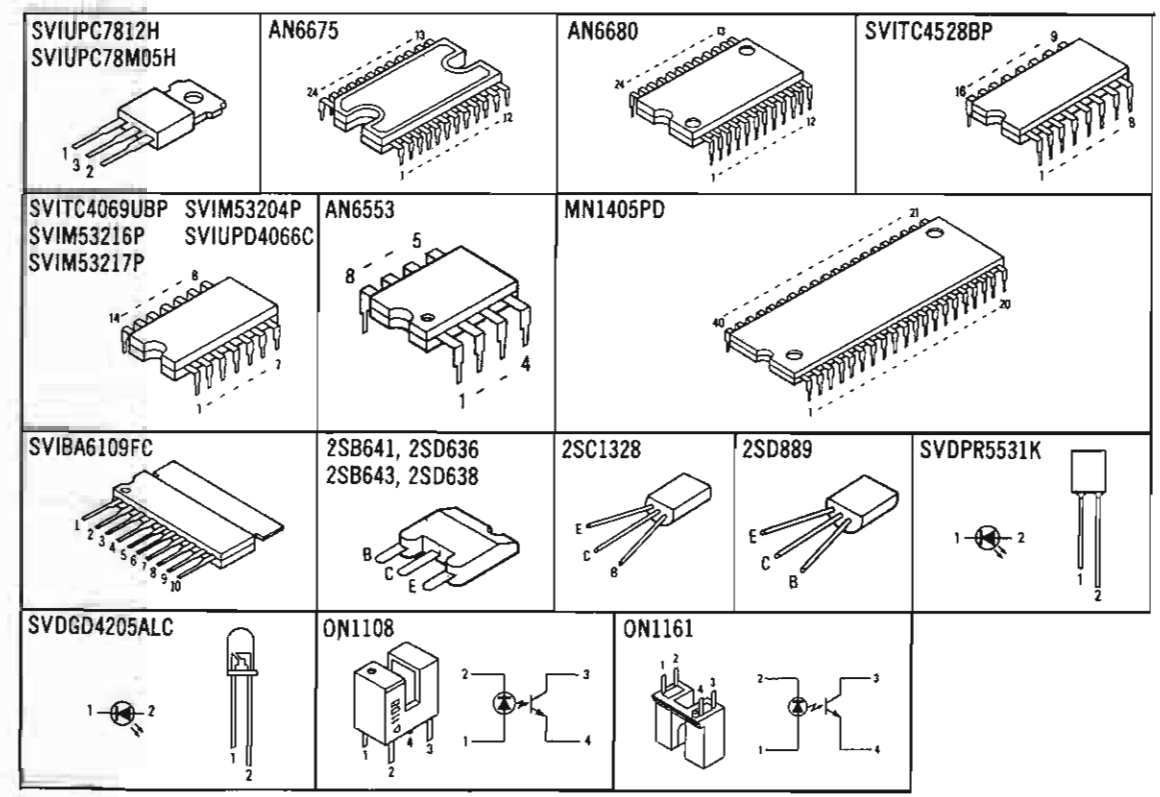

• Block diagram of IC's

